

Ausdrehen

Geeignet ab Bohrungsdurchmesser 2,7 mm.

Boring

For use in bores as of minimum bore diameter 2,7 mm.

Schnittwerte (Start) // Cutting parameters (start)

f	Vc
0,02 mm/U	(Seite/Page 442)

Passende Klemmhalter auf Seite // Suitable toolholders on page

40, 45, 46, 47, 48, 54, 55, 57, 64,
65, 68, 69, 70, 73, 75, 76, 78, 79,
80, 81

Vergleichbare Werkzeuge auf Seite // Similar tools on page

82



Legende
Legend 155



Oder besuchen Sie // Or visit
www.simtek.info/cp/1038



Abbildung zeigt / Drawing shows: A04.1820.30.42.05 Y R/L



Mehr Informationen zur Kühlmittelzufuhr finden Sie auf Seite 36
Additional information about through coolant supply on page 36

ØD	L2	ØDmin (Min. Bohrung) ØDmin (min. bore)	R	Kühlmittelzufuhr Through coolant supply	Artikelnummer Part number	Webcode www.simtek.com/webcode	Empfohlene Schneidstoffe Recommended cutting grades	a	d	f	LH	tmax	Connectcode www.simtek.com/code
mm	mm	mm	mm				PKMNSHO	mm	mm	mm	mm	mm	

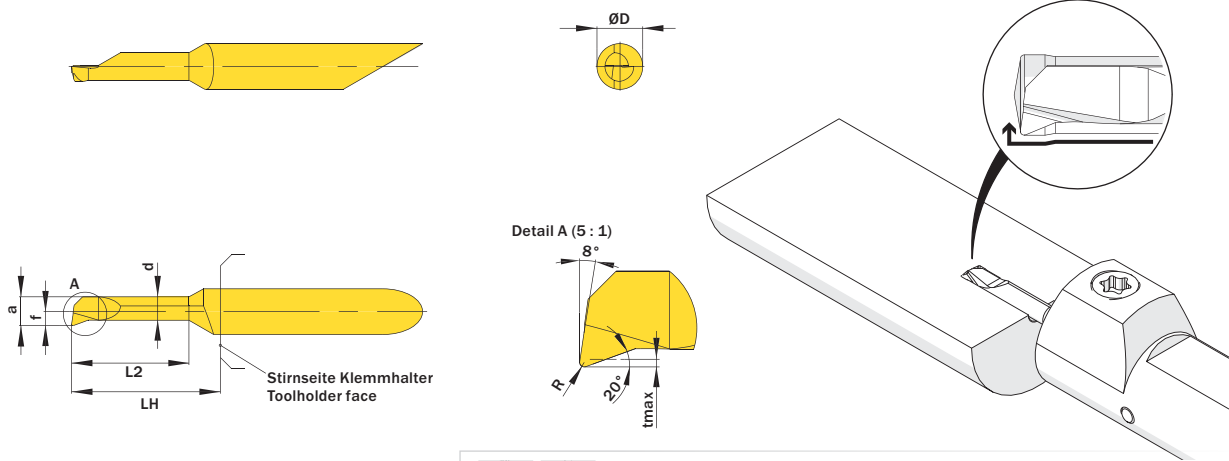
Fortgesetzte Tabelle
Continued Table

Verwandte Werkzeuge finden Sie auch auf der vorhergehenden Seite!
Related items can be found on the previous page as well!

▼ ØDmin (Min. Bohrung) // ØDmin (min. bore) = 2,7 mm

4,0	10,2	2,7	0,03	●	A04.1812.10.27.03 YR/L	R AKG6 L AHF1	X800 X400 X600 GX79 X500 X400	2,45	2,05	1,2	13,0	0,2	R	A04.R	L	A04.L
4,0	10,2	2,7	0,03	+	A04.1C12.10.27.03 YR/L	R AW9P L AXAH	X800 X400 X600 GX79 X500 X400	2,45	2,05	1,95	13,0	0,2	R	A04.CR	L	A04.CL
4,0	10,2	2,7	0,05	●	A04.1812.10.27.05 YR/L	R AFXD L AFVH	X800 X400 X600 GX79 X500 X400	2,45	2,05	1,2	13,0	0,2	R	A04.R	L	A04.L
4,0	10,2	2,7	0,05	+	A04.1C12.10.27.05 YR/L	R AW9Q L AXAJ	X800 X400 X600 GX79 X500 X400	2,45	2,05	1,95	13,0	0,2	R	A04.CR	L	A04.CL
4,0	10,2	2,7	0,15	●	A04.1812.10.27.15 YR/L	R AH2M L ACX1	X800 X400 X600 GX79 X500 X400	2,45	2,05	1,2	13,0	0,2	R	A04.R	L	A04.L
4,0	10,2	2,7	0,15	+	A04.1C12.10.27.15 YR/L	R AJ8J L AJØ1	X800 X400 X600 GX79 X500 X400	2,45	2,05	1,95	13,0	0,2	R	A04.CR	L	A04.CL
4,0	15,2	2,7	0,05	●	A04.1812.15.27.05 YR/L	R ANPQ L AEK2	X800 X400 X600 GX79 X500 X400	2,45	2,05	1,2	18,0	0,2	R	A04.R	L	A04.L
4,0	15,2	2,7	0,05	+	A04.1C12.15.27.05 YR/L	R AW9S L AXAK	X800 X400 X600 GX79 X500 X400	2,45	2,05	1,95	18,0	0,2	R	A04.CR	L	A04.CL
4,0	15,2	2,7	0,15	●	A04.1812.15.27.15 YR/L	R AA95 L AJKP	X800 X400 X600 GX79 X500 X400	2,45	2,05	1,2	18,0	0,2	R	A04.R	L	A04.L
4,0	15,2	2,7	0,15	+	A04.1C12.15.27.15 YR/L	R AB8C L AAQ1	X800 X400 X600 GX79 X500 X400	2,45	2,05	1,95	18,0	0,2	R	A04.CR	L	A04.CL
4,0	20,3	2,7	0,15	+	A04.1C12.20.27.15 YR	A2AC	X800 X400 X600 GX79 X500 X400	2,45	2,05	1,95	28,0	0,2				A04C.R

Verwandte Werkzeuge finden Sie auch auf der folgenden Seite!
Related items can be found on the following page as well!

Fortgesetzte Tabelle
Continued Table

Bestellbeispiel // Order example: A04.1812.10.27.15 YR X800 (R = Rechte Ausführung // Right hand version, X800 = Schneidstoff // Grade)