

Messerkopf

Fräserdorn-Aufnahme.

Milling Cutter

Milling arbor fixation.

Anzugsmoment (Schraube) // Tightening torque (screw)

“ASCC”: 6,0 Nm
 “ATKP”: 6,0 Nm

Bitte Hinweise im Anhang beachten // Please read add. notes

ALL (Seite/Page 678), H07 (Seite/Page 682)



Legende
 Legend **683**

Scan
 QR-Code

Oder besuchen Sie // Or Visit
www.simtek.info/cp/434



Abbildung zeigt / Drawing shows: M80.0063.05.IC R

Abbildung zu Illustrationszwecken "Rechte und Linke Werkzeuge"
 Image for illustration purpose of "Right and left hand tools"

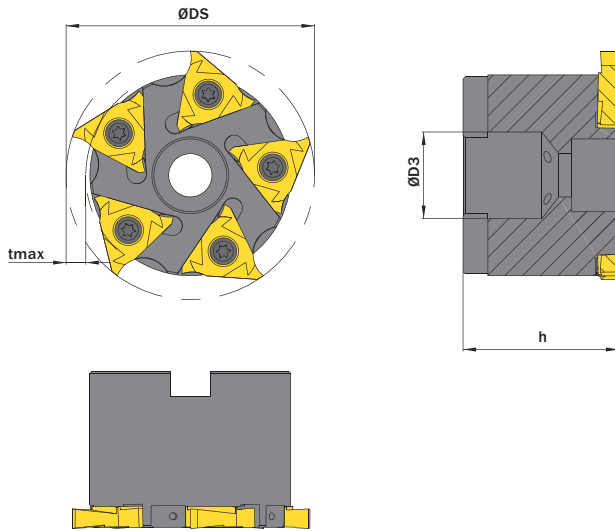
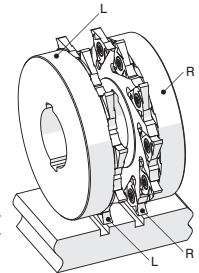

ØDS	ZEFP	Artikelnummer Part number	Webcode www.simtek.com/webcode	Mit Kühlmittelzufuhr With through coolant supply	ØD3	h	tmax	Schraube Screw	Schraubenschlüssel Screw driver	Connectcode www.simtek.com/code
mm					mm	mm	mm			
▼ ØDS = 63,0 mm										
63,0	5	M80.0063.05 R/L	R AHQX L AAKS	Nein / No	22,0	40,0	5,0	ASCC	T20R	R M14.R.6.0 L M14.L.6.0
63,0	5	M80.0063.05.07 R/L	R AW0W L AW0V	Nein / No	22,0	40,0	5,0	ATKP	T20R	R M14.R.7.0 L M14.L.7.0
63,0	5	M80.0063.05.07.IC R/L	R AW0Y L AW0X	Ja / Yes	22,0	40,0	5,0	ATKP	T20R	R M14.R.7.0 L M14.L.7.0
63,0	5	M80.0063.05.IC R/L	R AUGS L AVEH	Ja / Yes	22,0	40,0	5,0	ASCC	T20R	R M14.R.6.0 L M14.L.6.0
63,0	5	M80.2480.05 R/L	R AB23 L AW4F	Nein / No	19,05	40,0	5,0	ASCC	T20R	R M14.R.6.0 L M14.L.6.0
63,0	5	M80.2480.05.07 R/L	R AW01 L AW4G	Nein / No	19,05	40,0	5,0	ATKP	T20R	R M14.R.7.0 L M14.L.7.0
63,0	5	M80.2480.05.IC R	BD1Y	Ja / Yes	19,05	40,0	5,0	ASCC	T20R	M14.R.6.0 new
▼ ØDS = 80,0 mm										
80,0	8	M80.0080.08 R/L	R ADWY L AGDJ	Nein / No	27,0	32,0	5,0	ASCC	T20R	R M14.R.6.0 L M14.L.6.0
80,0	8	M80.0080.08.07 R/L	R AW00 L AW0Z	Nein / No	27,0	32,0	5,0	ATKP	T20R	R M14.R.7.0 L M14.L.7.0

Bestellbeispiel // Order example: **M80.0063.05 R** (R = Rechte Ausführung // Right hand version)

Eine Umschlüsselungsliste von Webcode zu Schrauben bzw. Spannmuttern finden Sie auf Seite 766.
 A conversion list from webcode to screws as well as standard screw nuts can be found on page 766.