

Vorstechen und Fasen

Geeignet ab Bohrungsdurchmesser 3,7 mm.

Pre-Part-Off and Chamfering

For use in bores as of minimum bore diameter 3,7 mm.

Schnittwerte (Start) // Cutting parameters (start)

f	Vc
0,02 mm/U	(Seite/Page 442)

Passende Klemmhalter auf Seite // Suitable toolholders on page

40, 41, 42, 45, 46, 47, 48, 49, 50,
54, 55, 56, 57, 58, 59, 64, 65, 68,
69, 70, 71, 73, 74, 75, 76, 77, 78,
79, 80, 81



SP
HM
R

Legende
Legend 155

Scan QR-Code Oder besuchen Sie // Or Visit
www.simtek.info/cp/779



Abbildung zeigt / Drawing shows: A05.0100.20.52 PR

Mehr Informationen zur Kühlmittelzufuhr finden Sie auf Seite 36
Additional information about through coolant supply on page 36

ØD	w	L2	ØDmin (Min. Bohrung) ØDmin (min. bore)	Kühlmittelzufuhr Through coolant supply	Artikelnummer Part number	Webcode www.simtek.com/webcode	Empfohlene Schneidstoffe Recommended cutting grades	a	d	f	LH	t	tmax	Connectcode www.simtek.com/code
mm	mm	mm	mm				P K M N S H O	mm	mm	mm	mm	mm	mm	
▼ ØDmin (Min. Bohrung) // ØDmin (min. bore) = 3,7 mm														
4,0	1,0	10,2	3,7	+	A04.0100.10.37 PR/L	R AEDE L AVEZ	X800 X400 X600 GX79 X500 X400	3,45	2,45	1,7	13,0	0,2	0,7	R A04.R A04C.R A04.L A04C.L
4,0	1,0	15,2	3,7	+	A04.0100.15.37 PR/L	R ACD1 L AVEØ	X800 X400 X600 GX79 X500 X400	3,45	2,45	1,7	18,0	0,2	0,7	R A04.R A04C.R A04.L A04C.L
▼ ØDmin (Min. Bohrung) // ØDmin (min. bore) = 4,2 mm														
4,0	1,0	20,3	4,2	+	A04.0100.20.42 PR/L	R AJ2W L AVE1	X800 X400 X600 GX79 X500 X400	3,95	2,95	1,95	23,0	0,2	0,7	R A04C.R L A04C.L
▼ ØDmin (Min. Bohrung) // ØDmin (min. bore) = 5,2 mm														
5,0	1,0	15,2	5,2	+	A05.0100.15.52 PR/L	R AFZX L AD7M	X800 X400 X600 GX79 X500 X400	4,95	3,75	2,45	18,0	0,2	0,7	R A05.R L A05.L
5,0	1,0	20,3	5,2	+	A05.0100.20.52 PR/L	R ADØE L ANDY	X800 X400 X600 GX79 X500 X400	4,95	3,75	2,45	23,0	0,2	0,7	R A05.R L A05.L
5,0	1,0	25,4	5,2	+	A05.0100.25.52 PR/L	R AHXE L AHFW	X800 X400 X600 GX79 X500 X400	4,95	3,75	2,45	28,0	0,2	0,7	R A05.R L A05.L
5,0	1,0	30,5	5,2	+	A05.0100.30.52 PR/L	R AG19 L AH2E	X800 X400 X600 GX79 X500 X400	4,95	3,75	2,45	33,0	0,2	0,7	R A05.R L A05.L
▼ ØDmin (Min. Bohrung) // ØDmin (min. bore) = 6,2 mm														
6,0	1,0	30,5	6,2	+	A06.0100.30.62 PR/L	R AFNW L AU6N	X800 X400 X600 GX79 X500 X400	5,95	3,95	2,95	33,0	0,2	0,7	R A06.R L A06.L
6,0	1,0	40,6	6,2	+	A06.0100.40.62 PR/L	R AB64 L AU6P	X800 X400 X600 GX79 X500 X400	5,95	3,95	2,95	43,0	0,2	0,7	R A06.R L A06.L

Bestellbeispiel // Order example: A05.0100.15.52 PR X800 (R = Rechte Ausführung // Right hand version, X800 = Schneidstoff // Grade)

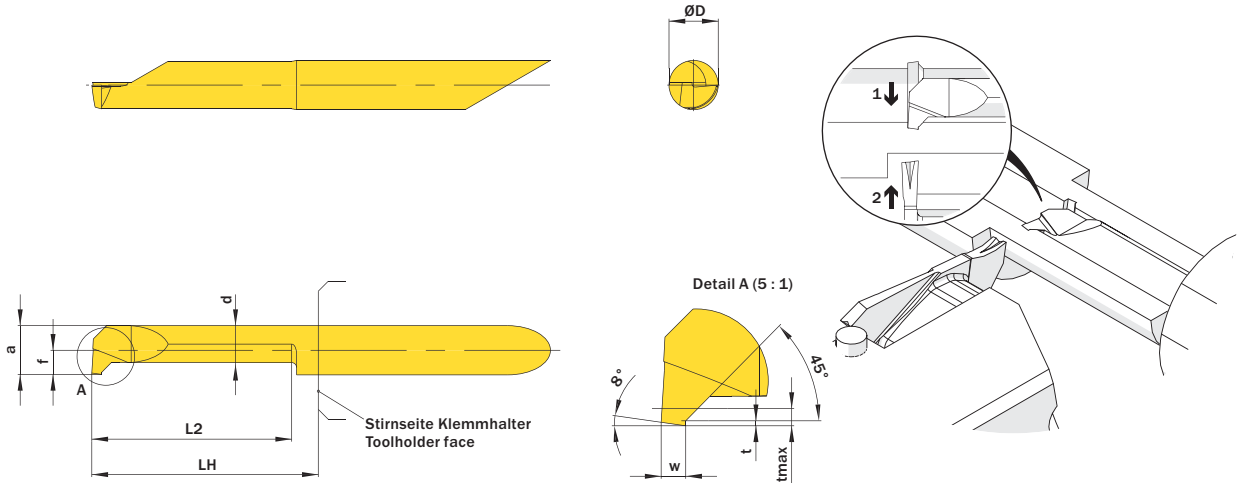
simturn AX

simturn DX

simturn PX

simturn H2

simturn K2

simturn GX

simturn E3

simturn E12

simturn FX

simturn Decolletage

simturn OA

Index