

# Klemmhalter, Innenbearbeitung, Rundschaft

Rundschaft mit innerer Kühlmittelzufuhr für die Größe A04.  
Vier Kühlmittelzufuhrarten je nach Bedarf einstellbar.

## Toolholder, Internal Applications, Round Shank

Round shank with through coolant for size A04. Four different types of through coolant supply can be realized as required.

Anzugsmoment (Schraube) // Tightening torque (screw)

**7,0 Nm**

Bitte Hinweise im Anhang beachten // Please read add. notes

**MASTER (Seite/Page 153)**



Legende  
Legend

155



Scan  
QR-Code

Oder besuchen Sie // Or Visit  
[www.simtek.info/cp/1200](http://www.simtek.info/cp/1200)

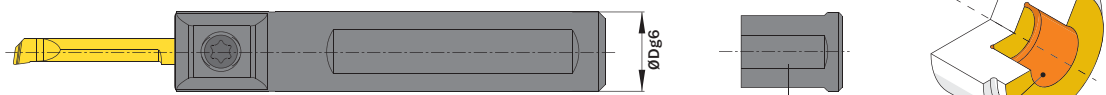
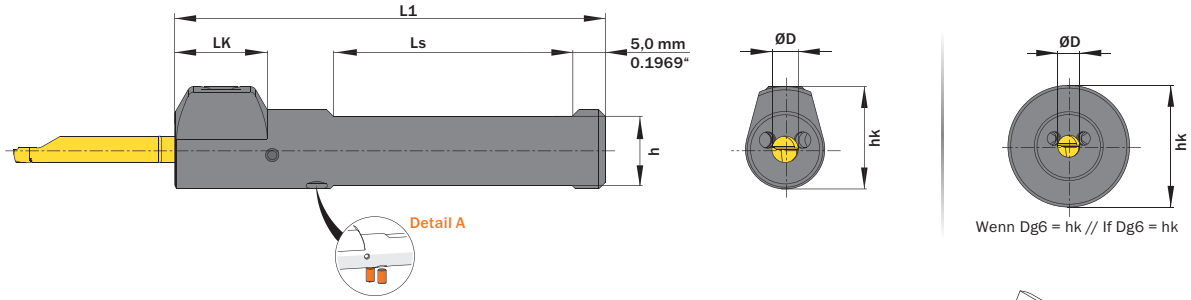

A...0020 / A...0022  
A...0025 / A...1.000  
4 Spannflächen // 4 Flats

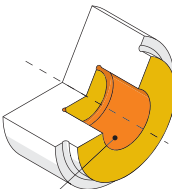

- Hauptsächlich geeignet für diese Flächen  
Mainly designed for these surfaces
- Je nach Schneidplatte ebenfalls möglich  
Also possible depending on insert type

ØD	ØDg6	Artikelnummer Part number	Webcode <a href="http://www.simtek.com/webcode">www.simtek.com/webcode</a>	h	hk	L1	LK	Ls	Anzahl Spannflächen Number of flats	Schraube Screw	Schraubenschlüssel Screw driver	Connectcode <a href="http://www.simtek.com/ccode">www.simtek.com/ccode</a>
mm	mm			mm	mm	mm	mm	mm				

Fortgesetzte Tabelle  
Continued Table

Verwandte Werkzeuge finden Sie auch auf der vorhergehenden Seite!  
Related items can be found on the previous page as well!

4,0	12,0	<b>A04.0012 T</b>	AUQY	10,5	15,5	70,0	14,0	41,0	2	ATKW	T15F	A04L A04.R A04CL A04C.R A04T
4,0	12,7	<b>A04.0.500 T</b>	A5H9	11,2	15,85	70,0	41,0	41,0	2	ATKW	T15F	
4,0	15,875	<b>A04.0.625 T</b>	A5H7	13,88	17,44	75,0	14,0	46,0	2	ATKW	T15F	
4,0	16,0	<b>A04.0016 T</b>	AUQ1	14,0	17,5	75,0	14,0	46,0	2	ATKW	T15F	
4,0	19,05	<b>A04.0.750 T</b>	AUSA	17,05	19,05	110,0	-	81,0	2	ATKW	T15F	
4,0	20,0	<b>A04.0020 T</b>	AUSP	18,0	20,0	90,0	-	61,0	4	ATKW	T15F	
4,0	22,0	<b>A04.0022 T</b>	AUST	20,0	22,0	110,0	-	90,0	4	ATKW	T15F	
4,0	25,0	<b>A04.0025 T</b>	AUSW	23,0	25,0	110,0	-	90,0	4	ATKW	T15F	
4,0	25,4	<b>A04.1.000 T</b>	AUSK	23,39	25,4	110,0	-	90,0	4	ATKW	T15F	

Verwandte Werkzeuge finden Sie auch auf der folgenden Seite!  
Related items can be found on the following page as well!

Fortgesetzte Tabelle  
Continued Table

Bestellbeispiel // Order example: **A04.0016 T**

Detail A | 1 Halter – 4 Kühlmittelzufuhrarten // 1 Toolholder – 4 types of coolant supply

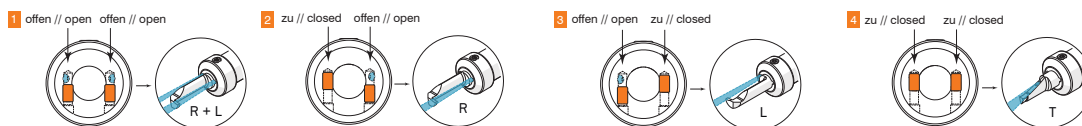

Eine Umschlüsselungliste von Webcode zu Schrauben bzw. Spannmuttern finden Sie auf Seite 766.  
A conversion list from webcode to screws as well as standard screw nuts can be found on page 766.