

Klemmhalter, Innenbearbeitung, Rundschaft

Rundschaft mit innerer Kühlmittelzufuhr für die Größe A04.
Vier Kühlmittelzufuhrarten je nach Bedarf einstellbar.

Toolholder, Internal Applications, Round Shank

Round shank with through coolant for size A04. Four different types of through coolant supply can be realized as required.

Anzugsmoment (Schraube) // Tightening torque (screw)

7,0 Nm

Bitte Hinweise im Anhang beachten // Please read add. notes

MASTER (Seite/Page 153)



Legende
Legend

155



Scan
QR-Code

Oder besuchen Sie // Or Visit
www.simtek.info/cp/1200

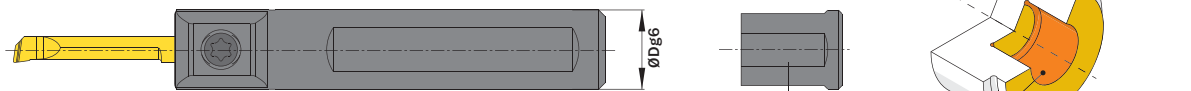
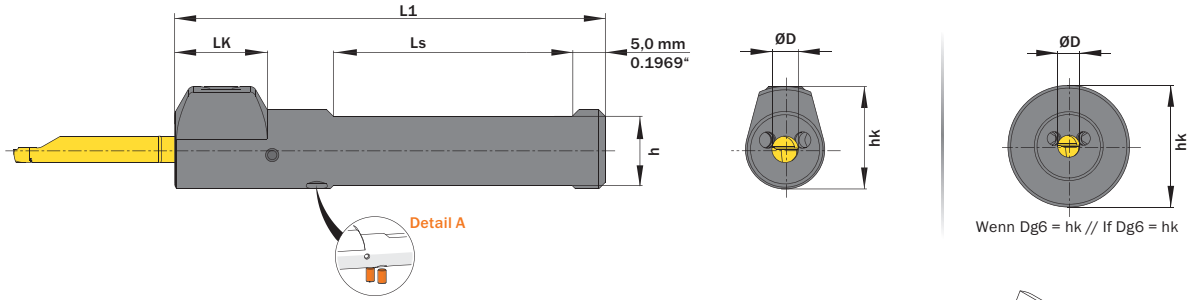

A...0020 / A...0022
A...0025 / A...1.000
4 Spannflächen // 4 Flats

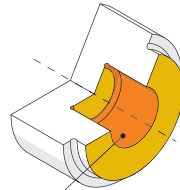

- Hauptsächlich geeignet für diese Flächen
Mainly designed for these surfaces
- Je nach Schneidplatte ebenfalls möglich
Also possible depending on insert type

ØD	ØDg6	Artikelnummer Part number	Webcode www.simtek.com/webcode	h	hk	L1	LK	Ls	Anzahl Spannflächen Number of flats	Schraube Screw	Schraubenschlüssel Screw driver	Connectcode www.simtek.com/ccode
mm	mm			mm	mm	mm	mm	mm				

Fortgesetzte Tabelle
Continued Table

Verwandte Werkzeuge finden Sie auch auf der vorhergehenden Seite!
Related items can be found on the previous page as well!

4,0	12,0	A04.0012 T	AUQY	10,5	15,5	70,0	14,0	41,0	2	ATKW	T15F	A04L A04.R A04CL A04C.R A04T
4,0	12,7	A04.0.500 T	A5H9	11,2	15,85	70,0	41,0	41,0	2	ATKW	T15F	
4,0	15,875	A04.0.625 T	A5H7	13,88	17,44	75,0	14,0	46,0	2	ATKW	T15F	
4,0	16,0	A04.0016 T	AUQ1	14,0	17,5	75,0	14,0	46,0	2	ATKW	T15F	
4,0	19,05	A04.0.750 T	AUSA	17,05	19,05	110,0	-	81,0	2	ATKW	T15F	
4,0	20,0	A04.0020 T	AUSP	18,0	20,0	90,0	-	61,0	4	ATKW	T15F	
4,0	22,0	A04.0022 T	AUST	20,0	22,0	110,0	-	90,0	4	ATKW	T15F	
4,0	25,0	A04.0025 T	AUSW	23,0	25,0	110,0	-	90,0	4	ATKW	T15F	
4,0	25,4	A04.1.000 T	AUSK	23,39	25,4	110,0	-	90,0	4	ATKW	T15F	

Verwandte Werkzeuge finden Sie auch auf der folgenden Seite!
Related items can be found on the following page as well!

Fortgesetzte Tabelle
Continued Table

Bestellbeispiel // Order example: **A04.0016 T**

Detail A | 1 Halter – 4 Kühlmittelzufuhrarten // 1 Toolholder – 4 types of coolant supply

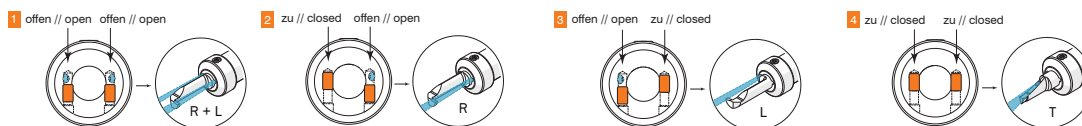

Eine Umschlüsselungliste von Webcode zu Schrauben bzw. Spannmuttern finden Sie auf Seite 766.
A conversion list from webcode to screws as well as standard screw nuts can be found on page 766.