

Ausdrehen mit spezieller Spantreppe

Mit optimierter Spanbildung durch spezielle Spantreppe. Zentrierte Ausführung für optimierte Kühlung und Spitzenhöhe in Verbindung mit passendem Halter. Geeignet ab Bohrungsdurchmesser 2,7 mm.

Boring with special chip former

Special chipformer for improved chip control. Centered edition with improved coolant supply and cutting edge positioning. For use in bores as of minimum bore diameter 2,7 mm.

Schnittwerte (Start) // Cutting parameters (start)

| | |
|-----------|------------------|
| f | Vc |
| 0,02 mm/U | (Seite/Page 442) |

Passende Klemmhalter auf Seite // Suitable toolholders on page

41, 45, 46, 47, 48, 49, 54, 55, 57,
58, 64, 65, 68, 69, 70, 73, 74, 75,
76, 78, 79, 80, 81



SP
HM
R

Legende
Legend 155

Scan
QR-Code

Oder besuchen Sie // Or Visit
www.simtek.info/cp/1045



Abbildung zeigt / Drawing shows: A04.0C17.15.37.15 YER



Mehr Informationen zur Kühlmittelzufuhr finden Sie auf Seite 36
Additional information about through coolant supply on page 36

| ØD | L2 | ØDmin (Min. Bohrung) ØDmin (min. bore) | R | Kühlmittelzufuhr Through coolant supply | Artikelnummer Part number | Webcode www.simtek.com/webcode | Empfohlene Schneidstoffe Recommended cutting grades | a | ap | d | f | LH | Connectcode www.simtek.com/code | |
|--|------|---|------|--|------------------------------|-----------------------------------|--|----------------|------|-----|------|------|------------------------------------|-------------------|
| mm | mm | mm | mm | | | | | mm | mm | mm | mm | mm | | |
| ▼ ØDmin (Min. Bohrung) // ØDmin (min. bore) = 2,7 mm | | | | | | | | | | | | | | |
| 4,0 | 10,2 | 2,7 | 0,15 | + | A04.0C12.10.27.15 YER/L | R AYE3 L AYE2 | X800 X400 X600 | GX79 X500 X400 | 2,45 | 0,4 | 2,3 | 1,95 | 13,0 | R A04C.R L A04C.L |
| 4,0 | 15,2 | 2,7 | 0,15 | + | A04.0C12.15.27.15 YER/L | R AUPY L AUPZ | X800 X400 X600 | GX79 X500 X400 | 2,45 | 0,4 | 2,3 | 1,95 | 18,0 | R A04C.R L A04C.L |
| ▼ ØDmin (Min. Bohrung) // ØDmin (min. bore) = 3,2 mm | | | | | | | | | | | | | | |
| 4,0 | 10,2 | 3,2 | 0,15 | + | A04.0C15.10.32.15 YER/L | R AYE5 L AYE4 | X800 X400 X600 | GX79 X500 X400 | 2,95 | 0,4 | 2,8 | 1,95 | 13,0 | R A04C.R L A04C.L |
| 4,0 | 15,2 | 3,2 | 0,15 | + | A04.0C15.15.32.15 YER/L | R AUPØ L AUP1 | X800 X400 X600 | GX79 X500 X400 | 2,95 | 0,4 | 2,8 | 1,95 | 18,0 | R A04C.R L A04C.L |
| ▼ ØDmin (Min. Bohrung) // ØDmin (min. bore) = 3,7 mm | | | | | | | | | | | | | | |
| 4,0 | 10,2 | 3,7 | 0,15 | + | A04.0C17.10.37.15 YER/L | R AYE6 L AYE7 | X800 X400 X600 | GX79 X500 X400 | 3,45 | 0,5 | 3,3 | 1,95 | 13,0 | R A04C.R L A04C.L |
| 4,0 | 15,2 | 3,7 | 0,15 | + | A04.0C17.15.37.15 YER/L | R AUPT L AUPS | X800 X400 X600 | GX79 X500 X400 | 3,45 | 0,5 | 3,3 | 1,95 | 18,0 | R A04C.R L A04C.L |
| 4,0 | 20,3 | 3,7 | 0,15 | + | A04.0C17.20.37.15 YER/L | R ATUE L ATUF | X800 X400 X600 | GX79 X500 X400 | 3,45 | 0,5 | 3,3 | 1,95 | 23,0 | R A04C.R L A04C.L |
| ▼ ØDmin (Min. Bohrung) // ØDmin (min. bore) = 4,2 mm | | | | | | | | | | | | | | |
| 4,0 | 10,2 | 4,2 | 0,15 | + | A04.0020.10.42.15 YER/L | R AVUP L AW4V | X800 X400 X600 | GX79 X500 X400 | 3,95 | 0,5 | 3,8 | 1,95 | 13,0 | R A04C.R L A04C.L |
| 4,0 | 15,2 | 4,2 | 0,15 | + | A04.0020.15.42.15 YER/L | R ASE4 L ASE5 | X800 X400 X600 | GX79 X500 X400 | 3,95 | 0,5 | 3,8 | 1,95 | 18,0 | R A04C.R L A04C.L |
| 4,0 | 15,2 | 4,2 | 0,4 | + | A04.0020.15.42.40 YER | A4XD | X800 X400 X600 | GX79 X500 X400 | 3,95 | 0,5 | 3,8 | 1,95 | 18,0 | A04C.R |
| 4,0 | 20,3 | 4,2 | 0,15 | + | A04.0020.20.42.15 YER/L | R ASE6 L ASE7 | X800 X400 X600 | GX79 X500 X400 | 3,95 | 0,5 | 3,8 | 1,95 | 23,0 | R A04C.R L A04C.L |
| 4,0 | 25,4 | 4,2 | 0,15 | + | A04.0020.25.42.15 YER/L | R AVUQ L AW4W | X800 X400 X600 | GX79 X500 X400 | 3,95 | 0,5 | 3,8 | 1,95 | 28,0 | R A04C.R L A04C.L |
| ▼ ØDmin (Min. Bohrung) // ØDmin (min. bore) = 5,2 mm | | | | | | | | | | | | | | |
| 5,0 | 10,2 | 5,2 | 0,2 | + | A05.0025.10.52.20 YER/L | R AS74 L AS75 | X800 X400 X600 | GX79 X500 X400 | 4,95 | 0,6 | 4,75 | 2,45 | 13,0 | R A05.R L A05.L |
| 5,0 | 10,2 | 5,2 | 0,4 | + | A05.0025.10.52.40 YER/L | R AY8B L AØ65 | X800 X400 X600 | GX79 X500 X400 | 4,95 | 0,6 | 4,75 | 2,45 | 13,0 | R A05.R L A05.L |
| 5,0 | 15,2 | 5,2 | 0,2 | + | A05.0025.15.52.20 YER/L | R AS77 L AS76 | X800 X400 X600 | GX79 X500 X400 | 4,95 | 0,6 | 4,75 | 2,45 | 18,0 | R A05.R L A05.L |
| 5,0 | 20,3 | 5,2 | 0,2 | + | A05.0025.20.52.20 YER/L | R ASE9 L ASE8 | X800 X400 X600 | GX79 X500 X400 | 4,95 | 0,6 | 4,75 | 2,45 | 23,0 | R A05.R L A05.L |
| 5,0 | 25,4 | 5,2 | 0,2 | + | A05.0025.25.52.20 YER/L | R ASFA L ASFB | X800 X400 X600 | GX79 X500 X400 | 4,95 | 0,6 | 4,75 | 2,45 | 28,0 | R A05.R L A05.L |
| 5,0 | 30,5 | 5,2 | 0,2 | + | A05.0025.30.52.20 YER/L | R AS79 L AS78 | X800 X400 X600 | GX79 X500 X400 | 4,95 | 0,6 | 4,75 | 2,45 | 33,0 | R A05.R L A05.L |

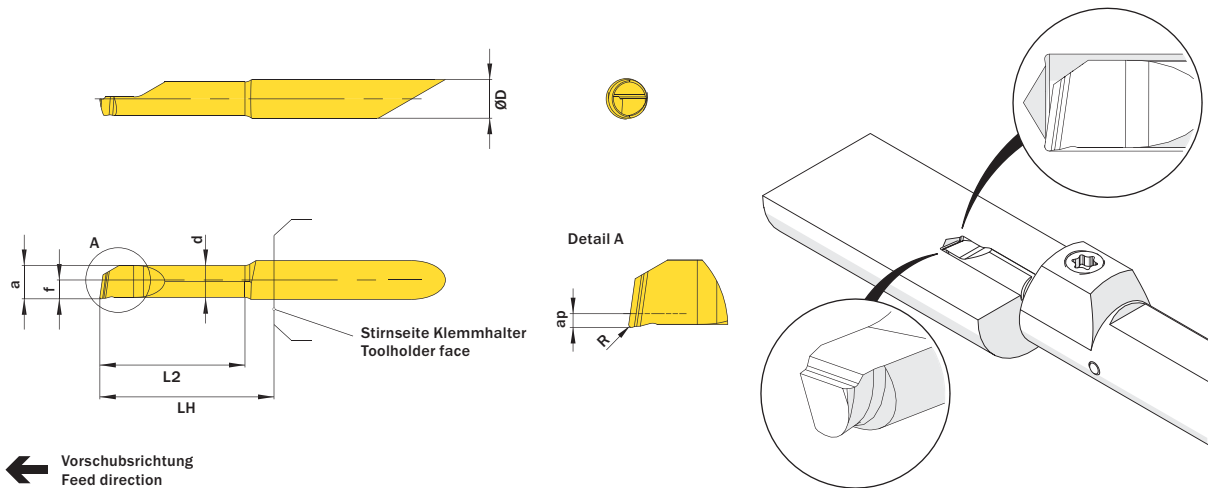
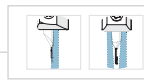
Bestellbeispiel // Order example: A05.0025.10.52.20 YER X800 (R = Rechte Ausführung // Right hand version, X800 = Schneidstoff // Grade)