

Ausdrehen mit spezieller Spantreppe

Mit optimierter Spanbildung durch spezielle Spantreppe. Zentrierte Ausführung für optimierte Kühlung und Spitzenhöhe in Verbindung mit passendem Halter. Geeignet ab Bohrungsdurchmesser 2,7 mm.

Boring with special chip former

Special chipformer for improved chip control. Centered edition with improved coolant supply and cutting edge positioning. For use in bores as of minimum bore diameter 2,7 mm.

Schnittwerte (Start) // Cutting parameters (start)	
f	Vc
0,02 mm/U	(Seite/Page 442)

Passende Klemmhalter auf Seite // Suitable toolholders on page
41, 45, 46, 47, 48, 49, 54, 55, 57, 58, 64, 65, 68, 69, 70, 73, 74, 75, 76, 78, 79, 80, 81

SP

HM

R

Legende
Legend

155

Oder besuchen Sie // Or Visit
www.simtek.info/cp/1045



Abbildung zeigt / Drawing shows: A04.0C17.15.37.15 YER



Mehr Informationen zur Kühlmittelzufuhr finden Sie auf Seite 36
Additional information about through coolant supply on page 36

ØD	L2	ØDmin (Min. Bohrung) ØDmin (min. bore)	R	Kühlmittelzufuhr Through coolant supply	Artikelnummer Part number	Webcode www.simtek.com/webcode	Empfohlene Schneidstoffe Recommended cutting grades	a	ap	d	f	LH	Connectcode www.simtek.com/code
mm	mm	mm	mm				P K M N S H O	mm	mm	mm	mm	mm	
▼ ØDmin (Min. Bohrung) // ØDmin (min. bore) = 2,7 mm													
4,0	10,2	2,7	0,15	+	A04.0C12.10.27.15 YER/L	R AYE3 L AYE2	X800 X400 GX79 X500 X400	2,45	0,4	2,3	1,95	13,0	R A04C.R L A04C.L
4,0	15,2	2,7	0,15	+	A04.0C12.15.27.15 YER/L	R AUPY L AUPZ	X800 X400 GX79 X500 X400	2,45	0,4	2,3	1,95	18,0	R A04C.R L A04C.L
▼ ØDmin (Min. Bohrung) // ØDmin (min. bore) = 3,2 mm													
4,0	10,2	3,2	0,15	+	A04.0C15.10.32.15 YER/L	R AYE5 L AYE4	X800 X400 GX79 X500 X400	2,95	0,4	2,8	1,95	13,0	R A04C.R L A04C.L
4,0	15,2	3,2	0,15	+	A04.0C15.15.32.15 YER/L	R AUPØ L AUP1	X800 X400 GX79 X500 X400	2,95	0,4	2,8	1,95	18,0	R A04C.R L A04C.L
▼ ØDmin (Min. Bohrung) // ØDmin (min. bore) = 3,7 mm													
4,0	10,2	3,7	0,15	+	A04.0C17.10.37.15 YER/L	R AYE6 L AYE7	X800 X400 GX79 X500 X400	3,45	0,5	3,3	1,95	13,0	R A04C.R L A04C.L
4,0	15,2	3,7	0,15	+	A04.0C17.15.37.15 YER/L	R AUPT L AUPS	X800 X400 GX79 X500 X400	3,45	0,5	3,3	1,95	18,0	R A04C.R L A04C.L
4,0	20,3	3,7	0,15	+	A04.0C17.20.37.15 YER/L	R ATUE L ATUF	X800 X400 GX79 X500 X400	3,45	0,5	3,3	1,95	23,0	R A04C.R L A04C.L
▼ ØDmin (Min. Bohrung) // ØDmin (min. bore) = 4,2 mm													
4,0	10,2	4,2	0,15	+	A04.0020.10.42.15 YER/L	R AVUP L AW4V	X800 X400 GX79 X500 X400	3,95	0,5	3,8	1,95	13,0	R A04C.R L A04C.L
4,0	15,2	4,2	0,15	+	A04.0020.15.42.15 YER/L	R ASE4 L ASE5	X800 X400 GX79 X500 X400	3,95	0,5	3,8	1,95	18,0	R A04C.R L A04C.L
4,0	15,2	4,2	0,4	+	A04.0020.15.42.40 YER	A4XD	X800 X400 GX79 X500 X400	3,95	0,5	3,8	1,95	18,0	A04C.R
4,0	20,3	4,2	0,15	+	A04.0020.20.42.15 YER/L	R ASE6 L ASE7	X800 X400 GX79 X500 X400	3,95	0,5	3,8	1,95	23,0	R A04C.R L A04C.L
4,0	25,4	4,2	0,15	+	A04.0020.25.42.15 YER/L	R AVUQ L AW4W	X800 X400 GX79 X500 X400	3,95	0,5	3,8	1,95	28,0	R A04C.R L A04C.L
▼ ØDmin (Min. Bohrung) // ØDmin (min. bore) = 5,2 mm													
5,0	10,2	5,2	0,2	+	A05.0025.10.52.20 YER/L	R AS74 L AS75	X800 X400 GX79 X500 X400	4,95	0,6	4,75	2,45	13,0	R A05.R L A05.L
5,0	10,2	5,2	0,4	+	A05.0025.10.52.40 YER/L	R AY8B L AØ65	X800 X400 GX79 X500 X400	4,95	0,6	4,75	2,45	13,0	R A05.R L A05.L
5,0	15,2	5,2	0,2	+	A05.0025.15.52.20 YER/L	R AS77 L AS76	X800 X400 GX79 X500 X400	4,95	0,6	4,75	2,45	18,0	R A05.R L A05.L
5,0	20,3	5,2	0,2	+	A05.0025.20.52.20 YER/L	R ASE9 L ASE8	X800 X400 GX79 X500 X400	4,95	0,6	4,75	2,45	23,0	R A05.R L A05.L
5,0	25,4	5,2	0,2	+	A05.0025.25.52.20 YER/L	R ASFA L ASFB	X800 X400 GX79 X500 X400	4,95	0,6	4,75	2,45	28,0	R A05.R L A05.L
5,0	30,5	5,2	0,2	+	A05.0025.30.52.20 YER/L	R AS79 L AS78	X800 X400 GX79 X500 X400	4,95	0,6	4,75	2,45	33,0	R A05.R L A05.L

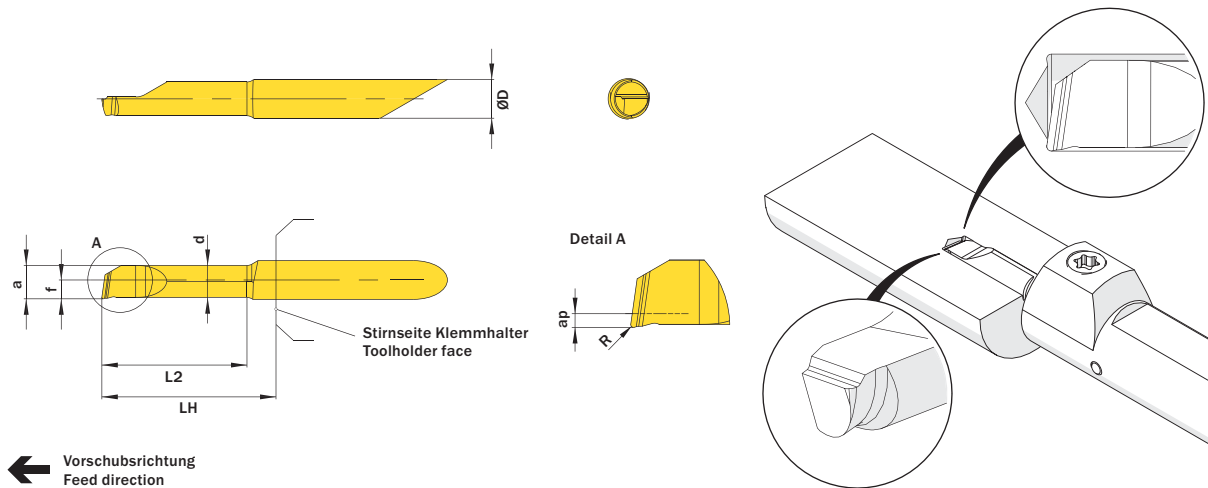
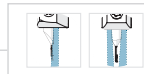
Bestellbeispiel // Order example: A05.0025.10.52.20 YER X800 (R = Rechte Ausführung // Right hand version, X800 = Schneidstoff // Grade)