

Nutenstechen

Geeignet ab Bohrungsdurchmesser 6,2 mm.

Grooving

For use in bores as of minimum bore diameter 6,2 mm.

Schnittwerte (Start) // Cutting parameters (start)

f	Vc
0,02 mm/U	(Seite/Page 442)

Passende Klemmhalter auf Seite // Suitable toolholders on page
42, 45, 50, 56, 59, 64, 65, 68, 69,
71, 74, 75, 77, 78, 79, 80, 81

Vergleichbare Werkzeuge auf Seite // Similar tools on page
121



Legende
Legend 155

Scan QR-Code Oder besuchen Sie // Or Visit
www.simtek.info/cp/797

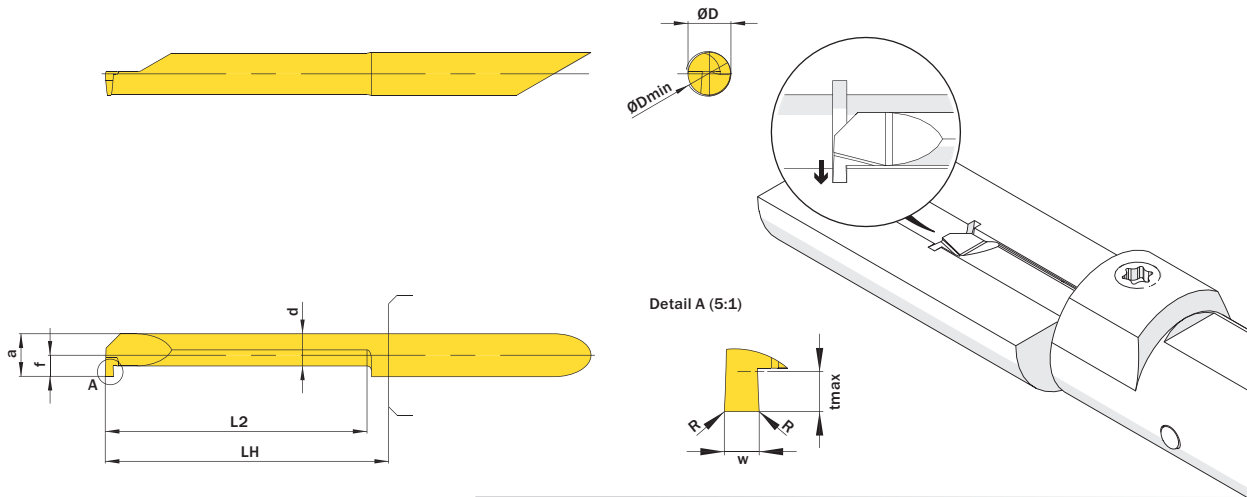

Mehr Informationen zur Kühlmittelzufuhr finden Sie auf Seite 36
Additional information about through coolant supply on page 36

ØD	w = 0,03	L2	ØDmin (Min. Bohrung) ØDmin (min. bore)	Kühlmittelzufuhr Through coolant supply	Artikelnummer Part number	Webcode www.simtek.com/webcode	Empfohlene Schneidstoffe Recommended cutting grades	a	d	f	LH	R	tmax	Connectcode www.simtek.com/code
mm	mm	mm	mm				P K M N S H O	mm	mm	mm	mm	mm	mm	

Fortgesetzte Tabelle Continued Table
Verwandte Werkzeuge finden Sie auch auf der vorhergehenden Seite!
Related Items can be found on the previous page as well!

▼ w = 1,0 mm														
6,0	1,0	10,2	6,2	+	A06.0100.10.62 GR/L	R APGK L ADY2	X800 X400 X600	GX79 X500 X400	5,95	3,95	2,95	13,0	-	1,8 R A06.R L A06.L
6,0	1,0	15,2	6,2	+	A06.0100.15.62 GR/L	R ACW8 L AH38	X800 X400 X600	GX79 X500 X400	5,95	3,95	2,95	18,0	-	1,8 R A06.R L A06.L
6,0	1,0	20,3	6,2	+	A06.0100.20.62 GR/L	R AJE6 L ADE3	X800 X400 X600	GX79 X500 X400	5,95	3,95	2,95	23,0	-	1,8 R A06.R L A06.L
6,0	1,0	25,4	6,2	+	A06.0100.25.62 GR/L	R AJXT L AKE0	X800 X400 X600	GX79 X500 X400	5,95	3,95	2,95	28,0	-	1,8 R A06.R L A06.L
6,0	1,0	30,5	6,2	+	A06.0100.30.62 GR/L	R AH78 L AK9S	X800 X400 X600	GX79 X500 X400	5,95	3,95	2,95	33,0	-	1,8 R A06.R L A06.L
6,0	1,0	35,6	6,2	+	A06.0100.35.62 GR/L	R AJ2E L AF63	X800 X400 X600	GX79 X500 X400	5,95	3,95	2,95	38,0	-	1,8 R A06.R L A06.L
6,0	1,0	40,6	6,2	+	A06.0100.40.62 GR/L	R AKTD L AN3W	X800 X400 X600	GX79 X500 X400	5,95	3,95	2,95	43,0	-	1,8 R A06.R L A06.L
▼ w = 1,168 mm														
6,0	1,168	10,2	6,2	+	A06.0117.10.62 GR/L	R AG4P L AFAB	X800 X400 X600	GX79 X500 X400	5,95	3,95	2,95	13,0	-	1,8 R A06.R L A06.L inch
6,0	1,168	10,2	6,2	+	A06.0117.10.62.10 GR	A5KT	X800 X400 X600	GX79 X500 X400	5,95	3,95	2,95	13,0	0,1	1,8 A06.R inch
6,0	1,168	15,2	6,2	+	A06.0117.15.62 GR/L	R ADAP L AA2N	X800 X400 X600	GX79 X500 X400	5,95	3,95	2,95	18,0	-	1,8 R A06.R L A06.L inch
6,0	1,168	20,3	6,2	+	A06.0117.20.62 GR/L	R ADH8 L ACUT	X800 X400 X600	GX79 X500 X400	5,95	3,95	2,95	23,0	-	1,8 R A06.R L A06.L inch
6,0	1,168	25,4	6,2	+	A06.0117.25.62 GR/L	R AC61 L APFG	X800 X400 X600	GX79 X500 X400	5,95	3,95	2,95	28,0	-	1,8 R A06.R L A06.L inch
6,0	1,168	30,5	6,2	+	A06.0117.30.62 GR/L	R AFN5 L AHPK	X800 X400 X600	GX79 X500 X400	5,95	3,95	2,95	33,0	-	1,8 R A06.R L A06.L inch
6,0	1,168	35,6	6,2	+	A06.0117.35.62 GR/L	R APS7 L ANN2	X800 X400 X600	GX79 X500 X400	5,95	3,95	2,95	38,0	-	1,8 R A06.R L A06.L inch
6,0	1,168	40,6	6,2	+	A06.0117.40.62 GR/L	R AA06 L APY3	X800 X400 X600	GX79 X500 X400	5,95	3,95	2,95	43,0	-	1,8 R A06.R L A06.L inch

Verwandte Werkzeuge finden Sie auch auf der folgenden Seite!
Related Items can be found on the following page as well!

Fortgesetzte Tabelle Continued Table

Bestellbeispiel // Order example: A06.0100.10.62 GR X800 (R = Rechte Ausführung // Right hand version, X800 = Schneidstoff // Grade)