

Bohrungen drehen

Geeignet ab Bohrungsdurchmesser 3,2 mm.

Boring

For use in bores as of minimum bore diameter 3,2 mm.

Schnittwerte (Start) // Cutting parameters (start)

f	Vc
0,02 mm/U	(Seite/Page 442)

Passende Klemmhalter auf Seite // Suitable toolholders on page

40, 41, 45, 46, 47, 48, 49, 54, 55,
57, 58, 64, 65, 68, 69, 70, 73, 74,
75, 76, 78, 79, 80, 81



SP
HM
R

Legende
Legend 155

Scan QR-Code Oder besuchen Sie // Or Visit
www.simtek.info/cp/754

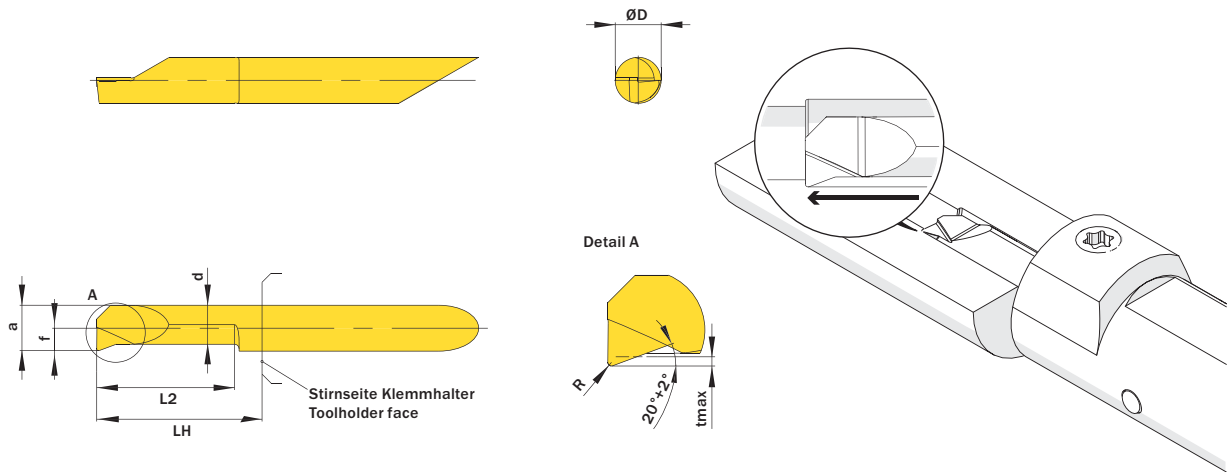

Abbildung zeigt / Drawing shows: A05.9025.15.52.20 Y R

Mehr Informationen zur Kühlmittelzufuhr finden Sie auf Seite 36
Additional information about through coolant supply on page 36

ØD	L2	ØDmin (Min. Bohrung) ØDmin (min. bore)	R	Kühlmittelzufuhr Through coolant supply	Artikelnummer Part number	Webcode www.simtek.com/webcode	Empfohlene Schneidstoffe Recommended cutting grades	a	d	f	LH	tmax	Connectcode www.simtek.com/code
mm	mm	mm	mm				PKMNSHO	mm	mm	mm	mm	mm	
▼ ØDmin (Min. Bohrung) // ØDmin (min. bore) = 3,2 mm													
4,0	12,2	3,2	0,15	+	A04.9015.12.32.15 YR/L	R APB9 L ADVC	X800 X400 X600 GX79 X500 X400	2,95	2,55	1,45	15,0	0,2	R A04.R L A04.L
▼ ØDmin (Min. Bohrung) // ØDmin (min. bore) = 4,2 mm													
4,0	15,2	4,2	0,15	+	A04.9020.15.42.15 YR/L	R APXB L ANKP	X800 X400 X600 GX79 X500 X400	3,95	3,45	1,95	18,0	0,3	R A04C.R L A04C.L
▼ ØDmin (Min. Bohrung) // ØDmin (min. bore) = 5,2 mm													
5,0	10,2	5,2	0,2	+	A05.9025.10.52.20 YR/L	R AJ84 L AHEC	X800 X400 X600 GX79 X500 X400	4,95	4,2	2,45	13,0	0,5	R A05.R L A05.L
5,0	15,2	5,2	0,2	+	A05.9025.15.52.20 YR/L	R AHSM L AKCD	X800 X400 X600 GX79 X500 X400	4,95	4,2	2,45	18,0	0,5	R A05.R L A05.L
5,0	20,3	5,2	0,2	+	A05.9025.20.52.20 YR/L	R AM84 L AJ5E	X800 X400 X600 GX79 X500 X400	4,95	4,2	2,45	23,0	0,5	R A05.R L A05.L

Bestellbeispiel // Order example: A04.9015.12.32.15 YR X800 (R = Rechte Ausführung // Right hand version, X800 = Schneidstoff // Grade)