

Ausdrehen

Geeignet ab Bohrungsdurchmesser 1,0 mm.

Boring

For use in bores as of minimum bore diameter 1,0 mm.

Schnittwerte (Start) // Cutting parameters (start)

f	Vc
0,02 mm/U	(Seite/Page 442)

Passende Klemmhalter auf Seite // Suitable toolholders on page

40, 45, 46, 47, 48, 54, 55, 57, 64,
65, 68, 69, 70, 73, 75, 76, 78, 79,
80, 81

Vergleichbare Werkzeuge auf Seite // Similar tools on page

82



SP
HM
R

Legende
Legend 155

Scan QR-Code Oder besuchen Sie // Or Visit
www.simtek.info/cp/1044



Abbildung zeigt / Drawing shows: A04.1820.30.42.05 Y R/L



Mehr Informationen zur Kühlmittelzufuhr finden Sie auf Seite 36
Additional information about through coolant supply on page 36

ØD	L2	ØDmin (Min. Bohrung) ØDmin (min. bore)	R	Kühlmittelzufuhr Through coolant supply	Artikelnummer Part number	Webcode www.simtek.com/webcode	Empfohlene Schneidstoffe Recommended cutting grades	a	d	f	LH	tmax	Connectcode www.simtek.com/code
mm	mm	mm	mm				PKMNSHO	mm	mm	mm	mm	mm	

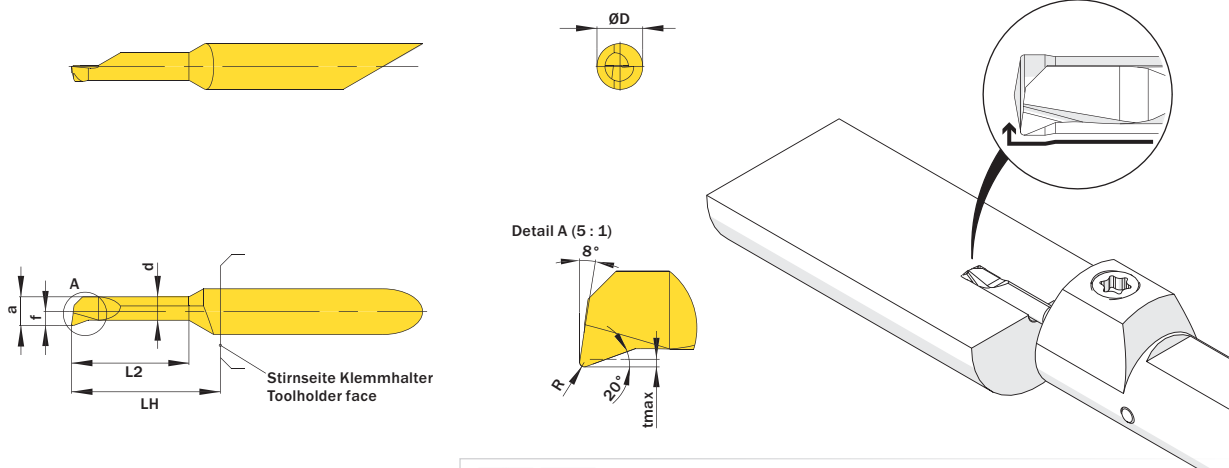
Fortgesetzte Tabelle
Continued Table

Verwandte Werkzeuge finden Sie auch auf der vorhergehenden Seite!
Related items can be found on the previous page as well!

▼ ØDmin (Min. Bohrung) // ØDmin (min. bore) = 1,0 mm																								
4,0	-	1,0	0,05	-	A04.1804.04.10.05 YR/L	R	AMGN	L	AK3Z	X800	X400 X600	GX79	X500	X400	0,95	0,65	0,45	13,0	0,1	R	A04.R	L	A04.L	upd
4,0	4,1	1,0	0,05	+	A04.1C04.04.10.05 YR/L	R	AW9G	L	AXAB	X800	X400 X600	GX79	X500	X400	0,95	0,65	1,95	13,0	0,1	R	A04.CR	L	A04.CL	
4,0	4,1	1,0	0,1	-	A04.1804.04.10.10 YR/L	R	AH77	L	ADKJ	X800	X400 X600	GX79	X500	X400	0,95	0,65	0,45	13,0	0,1	R	A04.R	L	A04.L	
4,0	4,1	1,0	0,1	+	A04.1C04.04.10.10 YR/L	R	AHJJ	L	AFJE	X800	X400 X600	GX79	X500	X400	0,95	0,65	1,95	13,0	0,1	R	A04.CR	L	A04.CL	
4,0	6,1	1,0	0,05	-	A04.1804.06.10.05 YR/L	R	AHGX	L	APQV	X800	X400 X600	GX79	X500	X400	0,95	0,65	0,45	13,0	0,1	R	A04.R	L	A04.L	
4,0	6,1	1,0	0,05	+	A04.1C04.06.10.05 YR/L	R	AW9H	L	AXAC	X800	X400 X600	GX79	X500	X400	0,95	0,65	1,95	13,0	0,1	R	A04.CR	L	A04.CL	
4,0	6,1	1,0	0,1	-	A04.1804.06.10.10 YR/L	R	ADN1	L	AASJ	X800	X400 X600	GX79	X500	X400	0,95	0,65	0,45	13,0	0,1	R	A04.R	L	A04.L	
4,0	6,1	1,0	0,1	+	A04.1C04.06.10.10 YR/L	R	AJGF	L	AMNZ	X800	X400 X600	GX79	X500	X400	0,95	0,65	1,95	13,0	0,1	R	A04.CR	L	A04.CL	
4,0	8,1	1,0	0,1	-	A04.1804.08.10.10 YR/L	R	AJHB	L	AEXS	X800	X400 X600	GX79	X500	X400	0,95	0,65	0,45	13,0	0,1	R	A04.R	L	A04.L	
4,0	8,1	1,0	0,1	+	A04.1C04.08.10.10 YR/L	R	ANWW	L	AJEK	X800	X400 X600	GX79	X500	X400	0,95	0,65	1,95	13,0	0,1	R	A04.CR	L	A04.CL	
▼ ØDmin (Min. Bohrung) // ØDmin (min. bore) = 1,2 mm																								
4,0	5,1	1,2	0,1	-	A04.1805.04.12.10 YR/L	R	A517	L	A519	X800	X400 X600	GX79	X500	X400	1,1	0,8	0,55	13,0	0,1	R	A04.R	L	A04.L	
4,0	5,1	1,2	0,1	+	A04.1C05.04.12.10 YR/L	R	AW3A	L	AW29	X800	X400 X600	GX79	X500	X400	1,1	0,8	1,95	13,0	0,1	R	A04.CR	L	A04.CL	
4,0	7,1	1,2	0,1	-	A04.1805.07.12.10 YR/L	R	A52D	L	A52B	X800	X400 X600	GX79	X500	X400	1,1	0,8	0,55	13,0	0,1	R	A04.R	L	A04.L	
4,0	7,1	1,2	0,1	+	A04.1C05.07.12.10 YR/L	R	AW3C	L	AW3B	X800	X400 X600	GX79	X500	X400	1,1	0,8	1,95	13,0	0,1	R	A04.CR	L	A04.CL	
4,0	9,1	1,2	0,1	-	A04.1805.09.12.10 YR/L	R	A52K	L	A52F	X800	X400 X600	GX79	X500	X400	1,1	0,8	0,55	13,0	0,1	R	A04.R	L	A04.L	
4,0	9,1	1,2	0,1	+	A04.1C05.09.12.10 YR/L	R	AW3E	L	AW3D	X800	X400 X600	GX79	X500	X400	1,1	0,8	1,95	13,0	0,1	R	A04.CR	L	A04.CL	

Verwandte Werkzeuge finden Sie auch auf der folgenden Seite!
Related items can be found on the following page as well!

Fortgesetzte Tabelle
Continued Table

Bestellbeispiel // Order example: A04.1804.06.10.10 YR X800 (R = Rechte Ausführung // Right hand version, X800 = Schneidstoff // Grade)