

Axialeinstiche in Bohrungen

Geeignet ab Bohrungsdurchmesser 14,0 mm.

Face Grooving in bores

For use in bores as of minimum bore diameter 14,0 mm.

Schnittwerte (Start) // Cutting parameters (start)

f	Vc
0,02 mm/U	Seite/Page 442

Passende Klemmhalter auf Seite // Suitable toolholders on page
182, 183, 184



Legende
Legend 238

Scan
QR-Code

Oder besuchen Sie // Or Visit
www.simtek.info/cp/818

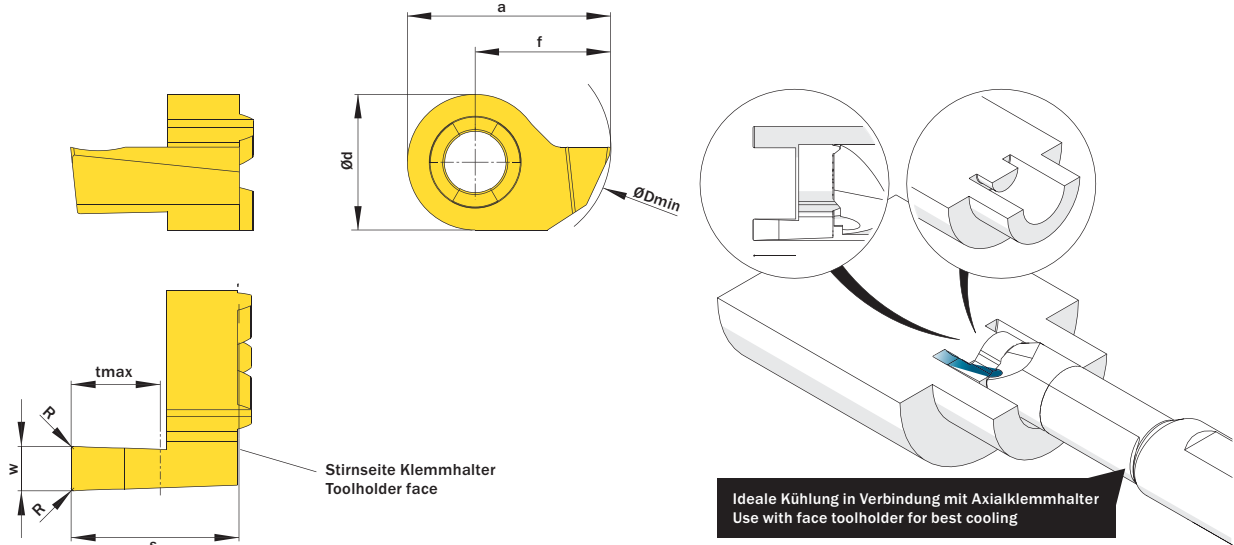

Abbildung zeigt / Drawing shows: D14.1430.62 A R

ØDmin (Min. Bohrung) ØDmin (min. bore)	w +0,03	R	tmax	Artikelnummer Part number	Webcode www.simtek.com/webcode	Empfohlene Schneidstoffe Tagesaktuelle Verfügbarkeit und Preise finden Sie auf www.simtek.com/webcode Recommended cutting grades You can find current availability and prices on www.simtek.com/webcode						a	Ød	f	S	Connectcode www.simtek.com/code
						P	K	M	N	S	H					
▼ tmax = 1,5 mm																
14,0	1,0	-	1,5	D14.1410.00 AR/L	R AB03 L AJC4	X800 X400 X600	GX79 X500 X400	13,5	9,0	9,0	8,3	R	D14.A.R	L	D14.A.L	
14,0	1,168	-	1,5	D14.1411.00 AR/L	R AA1G L AGEN	X800 X400 X600	GX79 X500 X400	13,5	9,0	9,0	8,3	R	D14.A.R	L	D14.A.L	inch
▼ tmax = 2,5 mm																
14,0	1,5	0,2	2,5	D14.1415.02 AR/L	R AET8 L ABZX	X800 X400 X600	GX79 X500 X400	13,5	9,0	9,0	8,3	R	D14.A.R	L	D14.A.L	
14,0	1,6	0,2	2,5	D14.1416.02 AR/L	R AC9S L AGVC	X800 X400 X600	GX79 X500 X400	13,5	9,0	9,0	8,3	R	D14.A.R	L	D14.A.L	
14,0	1,575	0,2	2,5	D14.1416.020 AR	A4VN	X800 X400 X600	GX79 X500 X400	13,5	9,0	9,0	8,3		D14.A.R			inch
▼ tmax = 3,0 mm																
14,0	2,0	0,2	3,0	D14.1420.02 AR/L	R AKZS L AG57	X800 X400 X600	GX79 X500 X400	13,5	9,0	9,0	8,3	R	D14.A.R	L	D14.A.L	upd
14,0	2,388	0,2	3,0	D14.1424.02 AR/L	R AF82 L AHNH	X800 X400 X600	GX79 X500 X400	13,5	9,0	9,0	8,3	R	D14.A.R	L	D14.A.L	inch
14,0	2,5	0,2	3,0	D14.1425.02 AR/L	R AMFK L AJNS	X800 X400 X600	GX79 X500 X400	13,5	9,0	9,0	8,3	R	D14.A.R	L	D14.A.L	
14,0	3,0	0,2	3,0	D14.1430.02 AR/L	R ABPP L AMDG	X800 X400 X600	GX79 X500 X400	13,5	9,0	9,0	8,3	R	D14.A.R	L	D14.A.L	
14,0	3,175	0,2	3,0	D14.1432.02 AR/L	R AHGE L AMA5	X800 X400 X600	GX79 X500 X400	13,5	9,0	9,0	8,3	R	D14.A.R	L	D14.A.L	inch
▼ tmax = 5,0 mm																
14,0	2,0	0,2	5,0	D14.1420.52 AR/L	R AGV5 L AATA	X800 X400 X600	GX79 X500 X400	13,5	9,0	9,0	10,3	R	D14.A.R	L	D14.A.L	
14,0	2,388	0,2	5,0	D14.1424.52 AR/L	R AF3H L AMMD	X800 X400 X600	GX79 X500 X400	13,5	9,0	9,0	10,3	R	D14.A.R	L	D14.A.L	inch
14,0	2,5	0,2	5,0	D14.1425.52 AR/L	R ACQN L AGFZ	X800 X400 X600	GX79 X500 X400	13,5	9,0	9,0	10,3	R	D14.A.R	L	D14.A.L	
14,0	3,0	0,2	5,0	D14.1430.52 AR/L	R AKV7 L AJKK	X800 X400 X600	GX79 X500 X400	13,5	9,0	9,0	10,3	R	D14.A.R	L	D14.A.L	
14,0	3,175	0,2	5,0	D14.1432.52 AR/L	R AGHH L ANZK	X800 X400 X600	GX79 X500 X400	13,5	9,0	9,0	10,3	R	D14.A.R	L	D14.A.L	inch
▼ tmax = 6,0 mm																
14,0	3,0	0,2	6,0	D14.1430.62 AR	AGU2	X800 X400 X600	GX79 X500 X400	13,5	9,0	9,0	11,3		D14.A.R			
▼ tmax = 10,0 mm																
18,0	3,0	0,2	10,0	D18.1830.10.02 AR/L	R AGNP L AVST	X800 X400 X600	GX79 X500 X400	16,5	11,0	11,0	15,8	R	D18.18.A.R	L	D18.18.A.L	
18,0	4,0	0,2	10,0	D18.1840.10.02 AR/L	R AVJW L AVSU	X800 X400 X600	GX79 X500 X400	17,0	11,0	11,5	15,8	R	D18.18.A.R	L	D18.18.A.L	

Bestellbeispiel // Order example: D14.1415.02 AR X800 (R = Rechte Ausführung // Right hand version, X800 = Schneidstoff // Grade)