

Ausdrehen

Geeignet ab Bohrungsdurchmesser 2,2 mm.

Boring

For use in bores as of minimum bore diameter 2,2 mm.

Schnittwerte (Start) // Cutting parameters (start)

f	Vc
0,02 mm/U	(Seite/Page 442)

Passende Klemmhalter auf Seite // Suitable toolholders on page

40, 45, 46, 47, 48, 54, 55, 57, 64,
65, 68, 69, 70, 73, 75, 76, 78, 79,
80, 81

Vergleichbare Werkzeuge auf Seite // Similar tools on page

82



Legende
Legend 155



Scan
QR-Code

Oder besuchen Sie // Or Visit
www.simtek.info/cp/1038



Abbildung zeigt / Drawing shows: A04.1820.30.42.05 Y R/L



Mehr Informationen zur Kühlmittelzufuhr finden Sie auf Seite 36
Additional information about through coolant supply on page 36

ØD	L2	ØDmin (Min. Bohrung) ØDmin (min. bore)	R	Kühlmittelzufuhr Through coolant supply	Artikelnummer Part number	Webcode www.simtek.com/webcode	Empfohlene Schneidstoffe Recommended cutting grades	a	d	f	LH	tmax	Connectcode www.simtek.com/code
mm	mm	mm	mm				PKMNSHO	mm	mm	mm	mm	mm	

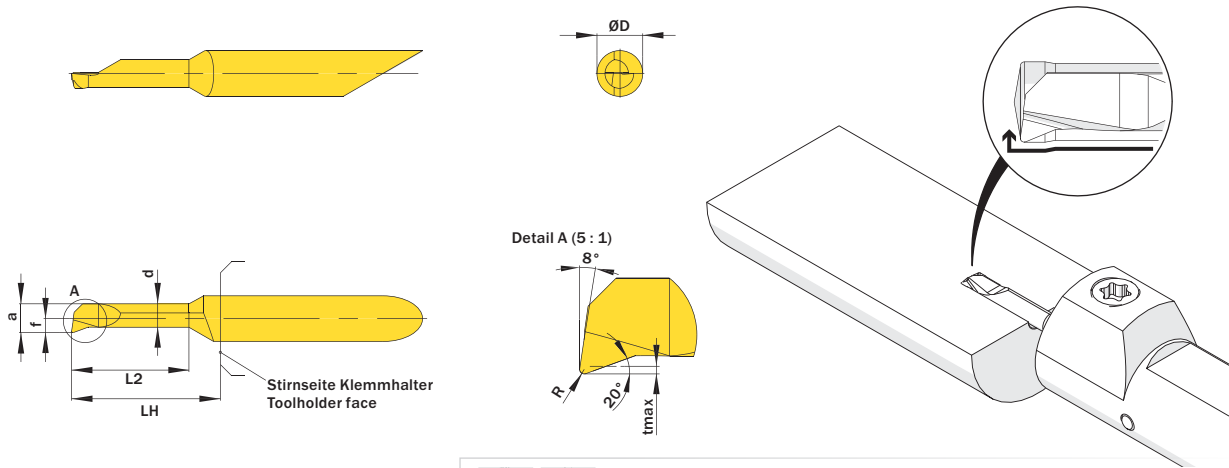
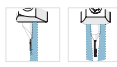
Fortgesetzte Tabelle
Continued Table

Verwandte Werkzeuge finden Sie auch auf der vorhergehenden Seite!
Related items can be found on the previous page as well!

▼ ØDmin (Min. Bohrung) // ØDmin (min. bore) = 2,2 mm

4,0	6,0	2,2	0,05	●	A04.1810.06.22.05 YR/L	R AEWL	L AHNE	X800	X400 X600	GX79	X500	X400	1,95	1,55	0,95	13,0	0,2	R	A04.R	L	A04.L	upd
4,0	6,0	2,2	0,05	+	A04.1C10.06.22.05 YR/L	R AW9M	L AXAF	X800	X400 X600	GX79	X500	X400	1,95	1,55	1,95	13,0	0,2	R	A04C.R	L	A04C.L	upd
4,0	6,0	2,2	0,1	●	A04.1810.06.22.10 YR/L	R AMKG	L ABK2	X800	X400 X600	GX79	X500	X400	1,95	1,55	0,95	13,0	0,2	R	A04.R	L	A04.L	upd
4,0	6,0	2,2	0,1	+	A04.1C10.06.22.10 YR/L	R ABCM	L AKQQ	X800	X400 X600	GX79	X500	X400	1,95	1,55	1,95	13,0	0,2	R	A04C.R	L	A04C.L	upd
4,0	9,1	2,2	0,05	●	A04.1810.09.22.05 YR/L	R AFEA	L AEVE	X800	X400 X600	GX79	X500	X400	1,95	1,55	0,95	13,0	0,2	R	A04.R	L	A04.L	
4,0	9,1	2,2	0,05	+	A04.1C10.09.22.05 YR/L	R AW9N	L AXAG	X800	X400 X600	GX79	X500	X400	1,95	1,55	1,95	13,0	0,2	R	A04C.R	L	A04C.L	
4,0	9,1	2,2	0,1	●	A04.1810.09.22.10 YR/L	R AM4S	L AA7F	X800	X400 X600	GX79	X500	X400	1,95	1,55	0,95	13,0	0,2	R	A04.R	L	A04.L	
4,0	9,1	2,2	0,1	+	A04.1C10.09.22.10 YR/L	R ABD9	L AMX3	X800	X400 X600	GX79	X500	X400	1,95	1,55	1,95	13,0	0,2	R	A04C.R	L	A04C.L	
4,0	13,2	2,2	0,1	●	A04.1810.13.22.10 YR/L	R AKP9	L AJ36	X800	X400 X600	GX79	X500	X400	1,95	1,55	0,95	18,0	0,2	R	A04.R	L	A04.L	
4,0	13,2	2,2	0,1	+	A04.1C10.13.22.10 YR/L	R AGGH	L AEBZ	X800	X400 X600	GX79	X500	X400	1,95	1,55	1,95	18,0	0,2	R	A04C.R	L	A04C.L	
4,0	15,2	2,2	0,1	+	A04.1C10.15.22.10 YR		A2AB	X800	X400 X600	GX79	X500	X400	1,95	1,55	1,95	23,0	0,2				A04C.R	

Verwandte Werkzeuge finden Sie auch auf der folgenden Seite!
Related items can be found on the following page as well!

Fortgesetzte Tabelle
Continued Table

Bestellbeispiel // Order example: A04.1812.10.27.15 YR X800 (R = Rechte Ausführung // Right hand version, X800 = Schneidstoff // Grade)