

Klemmhalter, Außen, Mittlere Stechtiefen

Einstechdrehen und Längsdrehen außen.
 Ausgewogene Balance zwischen Stechtiefe und Stabilität.

Toolholder, External, Regular Cutting Depths

External grooving and turning.
 Well-balanced ratio of cutting depth and stability.

Anzugsmoment (Schraube) // Tightening torque (screw)

12,0 Nm



TW **ST** **R** Legende Legend 327

Scan QR-Code Oder besuchen Sie // Or Visit www.simtek.info/cp/515

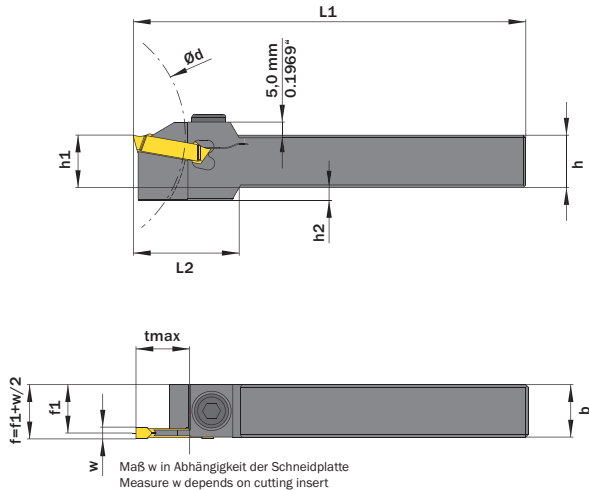

tmax in Abhängigkeit vom Werkstückdurchmesser (Ød)
 tmax depends on workpiece diameter (Ød)

	tmax bei / for Schaft bis 25,0 mm Shank up to 0.9843"	tmax bei / for Schaft 32,0 mm Shank 1.2598"
Bis Ø63,0 mm / up to Ø2.4803"	20,0 mm / 0.7874"	20,0 mm / 0.7874"
Bis Ø100,0 mm / up to Ø3.9370"	20,0 mm / 0.7874"	20,0 mm / 0.7874"
Bis Ø160,0 mm / up to Ø6.2992"	18,6 mm / 0.7323"	17,4 mm / 0.6850"
Bis Ø250,0 mm / up to Ø9.8425"	17,1 mm / 0.6732"	14,9 mm / 0.5866"
Bis Ø400,0 mm / up to Ø15.7480"	16,1 mm / 0.6339"	13,3 mm / 0.5236"

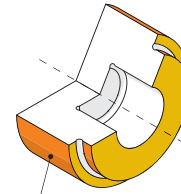

- Hauptsächlich geeignet für diese Flächen
 Mainly designed for these surfaces
- Je nach Schneidplatte/Aufnahme ebenfalls möglich
 Also possible depending on insert/fixation type

Abbildung zeigt / Drawing shows: G18.2020.03 R

h	b	w ≥	w ≤	Artikelnummer Part number	Webcode www.simtek.com/webcode	f1	h1 ^{js14}	h2	L1	L2	tmax	Schraube Screw	Schraubenschlüssel Screw driver	Connectcode www.simtek.com/code	Inch
▼ Connectcode = G29.02															
15,875	15,875	2,0	2,9	G18.0.625.02 R/L	R AAS0 L AJ1G	14,88	15,88	9,0	125,0	40,0	20,0	ATJ7	SW6	G29.02	Inch
19,05	19,05	2,0	2,9	G18.0.750.02 R/L	R A3T9 L A3T7	18,05	19,05	6,0	125,0	40,0	20,0	ATJ7	SW6	G29.02	Inch
25,4	25,4	2,0	2,9	G18.1.000.02 R/L	R AWCN L AWCM	24,4	25,4	-	150,0	-	20,0	ATJ7	SW6	G29.02	Inch
16,0	16,0	2,0	2,9	G18.1616.02 R/L	R APV6 L AN1Q	15,0	16,0	9,0	125,0	40,0	20,0	ATJ7	SW6	G29.02	
20,0	20,0	2,0	2,9	G18.2020.02 R/L	R AJX8 L ADGW	19,0	20,0	5,0	125,0	40,0	20,0	ATJ7	SW6	G29.02	
25,0	25,0	2,0	2,9	G18.2525.02 R/L	R AK6D L AEY4	24,0	25,0	-	150,0	-	20,0	ATJ7	SW6	G29.02	
▼ Connectcode = G29.03															
15,875	15,875	3,0	4,0	G18.0.625.03 R/L	R ADD3 L AAVX	14,32	15,88	9,0	125,0	40,0	20,0	ATJ7	SW6	G29.03	Inch
19,05	19,05	3,0	4,0	G18.0.750.03 R/L	R ADZB L AJQY	17,55	19,05	6,0	125,0	40,0	20,0	ATJ7	SW6	G29.03	Inch
25,4	25,4	3,0	4,0	G18.1.000.03 R/L	R AG8W L AKK8	23,9	25,4	-	150,0	-	20,0	ATJ7	SW6	G29.03	Inch
16,0	16,0	3,0	4,0	G18.1616.03 R/L	R AJW3 L AMND	14,5	16,0	9,0	125,0	40,0	20,0	ATJ7	SW6	G29.03	
20,0	20,0	3,0	4,0	G18.2020.03 R/L	R AN7Y L AF13	18,5	20,0	5,0	125,0	40,0	20,0	ATJ7	SW6	G29.03	
25,0	25,0	3,0	4,0	G18.2525.03 R/L	R AE4N L ABPE	23,5	25,0	-	150,0	-	20,0	ATJ7	SW6	G29.03	
32,0	25,0	3,0	4,0	G18.3225.03 R/L	R AJTX L AB4U	23,5	32,0	-	170,0	-	20,0	ATJ7	SW6	G29.03	

Verwandte Werkzeuge finden Sie auch auf der folgenden Seite!
 Related Items can be found on the following page as well!

Fortgesetzte Tabelle
 Continued Table

Bestellbeispiel // Order example: **G18.2525.03 R** (R = Rechte Ausführung // Right hand version)

Eine Umschlüsselungsliste von **Webcode zu Schrauben bzw. Spannmuttern** finden Sie auf Seite 766.
 A conversion list from **webcode to screws as well as standard screw nuts** can be found on page 766.

simturn AX
 simturn DX
 simturn PX
 simturn H2
 simturn K2
 simturn GX
 simturn E3
 simturn E12
 simturn FX
 simturn Decolletage
 simturn OA
 Index