

Halbzeuge, Formstechen

Halbzeuge für komponenten- und kundenspezifische Formeinstiche.

Semi-Finished-Insert, Profiling

Semi-finished-insert for component and client specific forms.

Passende Klemhalter auf Seite // Suitable toolholders on page
430, 431

SP Legende
HM Legend
436

Scan QR-Code Oder besuchen Sie // Or Visit
www.simtek.info/cp/728

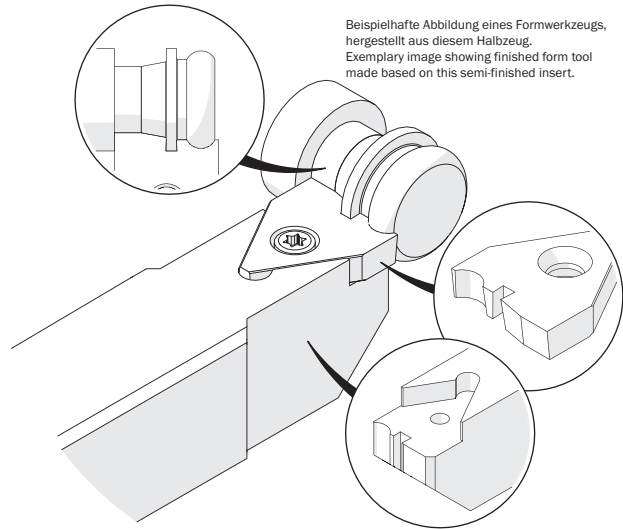
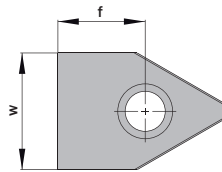
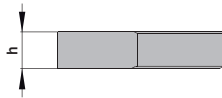

Beispielhafte Abbildung eines Formwerkzeugs, hergestellt aus diesem Halbzeug.
 Exemplary image showing finished form tool made based on this semi-finished insert.

Abbildung zeigt / Drawing shows: F12.1612.00 M

w	f	Artikelnummer Part number	Webcode www.simtek.com/webcode	h ^{+0,05}	Connectcode www.simtek.com/ccode
mm	mm			mm	
▼ w = 12,3 mm					
12,3	10,7	F12.1210.00 M	AMWH	5,0	TF12.A.12.10 TF12.B.12.10
12,3	15,2	F12.1215.00 M	AG2E	5,0	TF12.A.12.15 TF12.B.12.15
▼ w = 16,3 mm					
16,3	12,2	F12.1612.00 M	AKWQ	5,0	TF12.A.16.12 TF12.B.16.12
16,3	15,2	F12.1615.00 M	AECD	5,0	TF12.A.16.15 TF12.B.16.15
▼ w = 20,3 mm					
20,3	15,2	F12.2015.00 M	AA30	5,0	TF12.A.20.15 TF12.B.20.15
▼ w = 25,3 mm					
25,3	15,2	F12.2515.00 M	AGXU	5,0	TF12.A.25.15 TF12.B.25.15

Bestellbeispiel // Order example: **F12.1210.00 M X800** (X800 = Schneidstoff // Grade)