

Klemmhalter für Nutstoßaggregate

Geeignet für das Nutstoßen von Standard- und Sonderprofilen auf Nutstoßaggregat „Benz LinA“ und „EWS Slot“. Mit ME - Spannprinzip.

Toolholder for broaching units

For broaching of standard and special profiles on broaching unit „Benz LinA“ and „EWS Slot“. With ME clamping system.

Vergleichbare Werkzeuge auf Seite // Similar tools on page **697**

Max. Kühlmitteldruck // max. coolant pressure
10 bar

Bitte Hinweise im Anhang beachten // Please read add. notes

Wichtige Hinweise // Important hints (Seite/Page 763)



Legende
Legend

764

Scan
QR-Code

Oder besuchen Sie // Or Visit
www.simtek.info/cp/1381

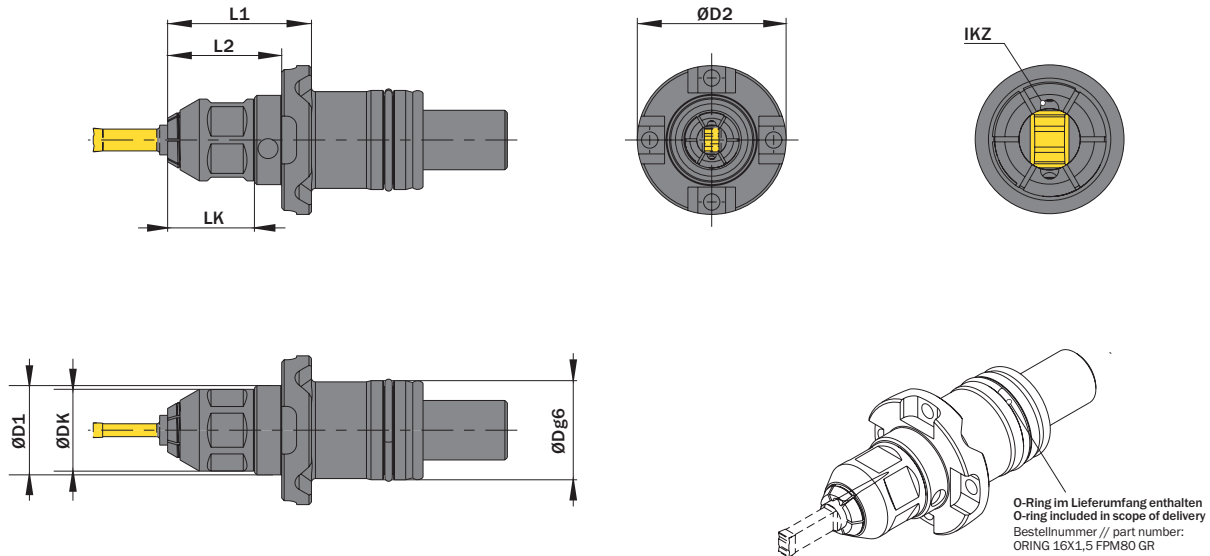

Abbildung zeigt / Drawing shows: A06.SB20.ME-B IC

Für Nutstoßaggregat For broaching unit	ØDg6	L2	L1	Artikelnummer Part number	Webcode www.simtek.com/webcode	ØDK	ØD1	ØD2	L3 (Max. Bohrungstiefe) L3 (max. depth of bore)	LK	Mutter Screw nut	Prismen-Fixiersystem Variante Prism fixation system variant	Connectcode www.simtek.com/code
	mm	mm	mm										
BENZ LinA 4.0/ EWS P20	20,0	23,0	29,0	A06.SB20.ME-B IC	A61Z	16,5	18,0	30,0	68,5	17,5	AYXS	1+3	BA06
BENZ LinA 4.0/ EWS P20	20,0	23,0	29,0	A07.SB20.ME-B IC	A611	16,5	18,0	30,0	68,5	17,5	AYXS	1+3	BA07
BENZ LinA 4.0/ EWS P20	20,0	28,0	34,0	A10.SB20.ME-B IC	A613	19,0	19,0	30,0	73,5	17,5	AYXS	1+3	BA10

Bestellbeispiel // Order example: **A07.SB20.ME-B IC**

Eine Umschlüsselungsliste von **Webcode zu Schrauben bzw. Spannmuttern** finden Sie auf Seite **766**.
A conversion list from **webcode to screws as well as standard screw nuts** can be found on page **766**.