

Klemmhalter, Innenbearbeitung

Geeignet zum Fräsen und Ausspindeln.

Toolholder, Internal Applications

For milling and boring applications.

Anzugsmoment (Schraube) // Tightening torque (screw)

7,0 Nm

Bitte Hinweise im Anhang beachten // Please read add. notes

MASTER (Seite/Page 153)



Legende
Legend

155



Scan
QR-Code

Oder besuchen Sie // Or Visit
www.simtek.info/cp/743

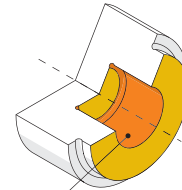
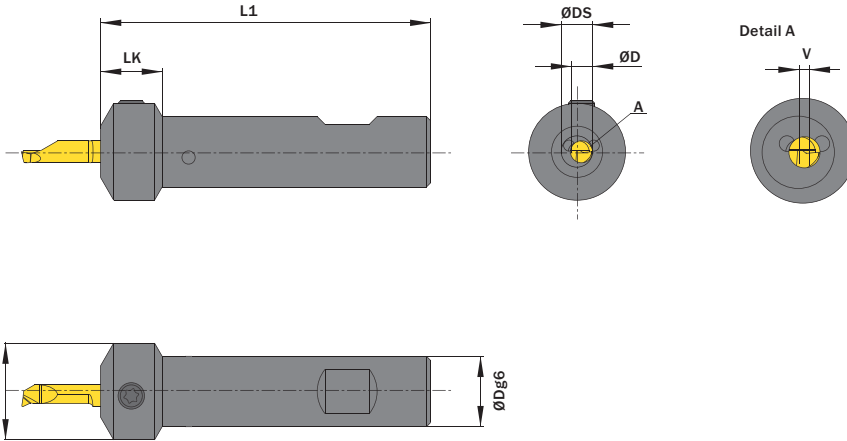

- Hauptsächlich geeignet für diese Flächen
Mainly designed for these surfaces
- Je nach Schneidplatte ebenfalls möglich
Also possible depending on insert type

Abbildung zeigt / Drawing shows: A05.0016.07 B ST

ØD	ØDg6	ØDS	Artikelnummer Part number	Webcode www.simtek.com/webcode	ØDk	L1	LK	V	Schraube Screw	Schraubenschlüssel Screw driver	Connectcode www.simtek.com/code	
mm	mm	mm			mm	mm	mm	mm				
▼ ØD = 4,0 mm												
4,0	15,875	5,9	A04.0.625.05 B ST	A5U7	21,0	75,0	14,0	1,0	ATKW	T15F	A04.L A04.R	Inch
4,0	16,0	5,9	A04.0016.05 B ST	APUS	21,0	75,0	14,0	1,0	ATKW	T15F	A04.L A04.R	
4,0	16,0	6,0	A04.0016.06 B ST	AB4A	21,0	75,0	14,0	1,05	ATKW	T15F	A04.L A04.R	
▼ ØD = 5,0 mm												
5,0	15,875	6,9	A05.0.625.07 B ST	A5U9	22,0	75,0	14,0	1,0	ATKW	T15F	A05.L A05.R	Inch
5,0	16,0	6,9	A05.0016.07 B ST	AMBQ	22,0	75,0	14,0	1,0	ATKW	T15F	A05.L A05.R	
5,0	16,0	7,5	A05.0016.08 B ST	AE97	22,0	75,0	14,0	1,3	ATKW	T15F	A05.L A05.R	
▼ ØD = 6,0 mm												
6,0	15,875	9,8	A06.0.625.10 B ST	A5VB	22,0	75,0	14,0	1,95	ATKW	T15F	A06.L A06.R	Inch
6,0	16,0	9,8	A06.0016.10 B ST	AC9M	22,0	75,0	14,0	1,95	ATKW	T15F	A06.L A06.R	
▼ ØD = 7,0 mm												
7,0	15,875	12,7	A07.0.625.13 B ST	A5VD	22,0	75,0	14,0	2,9	ATKW	T15F	A07.L A07.R	Inch
7,0	16,0	12,7	A07.0016.13 B ST	AH14	22,0	75,0	14,0	2,9	ATKW	T15F	A07.L A07.R	

Bestellbeispiel // Order example: **A04.0016.05 B ST**

Eine Umschlüsselungliste von **Webcode zu Schrauben bzw. Spannmuttern** finden Sie auf Seite 766.
A conversion list from **webcode to screws as well as standard screw nuts** can be found on page 766.