

Ausdrehen

Geeignet ab Bohrungsdurchmesser 3,0 mm.

Boring

For use in bores as of minimum bore diameter 3,0 mm.

Schnittwerte (Start) // Cutting parameters (start)

f	Vc
0,02 mm/U	(Seite/Page 442)

Passende Klemmhalter auf Seite // Suitable toolholders on page

40, 45, 46, 47, 48, 54, 55, 57, 64,
65, 68, 69, 70, 73, 75, 76, 78, 79,
80, 81

Vergleichbare Werkzeuge auf Seite // Similar tools on page

82



Legende
Legend 155

Scan QR-Code Oder besuchen Sie // Or Visit
www.simtek.info/cp/1039



Abbildung zeigt / Drawing shows: A04.1820.30.42.05 Y R/L



Mehr Informationen zur Kühlmittelzufuhr finden Sie auf Seite 36
Additional information about through coolant supply on page 36

ØD	L2	ØDmin (Min. Bohrung) ØDmin (min. bore)	R	Kühlmittelzufuhr Through coolant supply	Artikelnummer Part number	Webcode www.simtek.com/webcode	Empfohlene Schneidstoffe Recommended cutting grades	a	d	f	LH	tmax	Connectcode www.simtek.com/code
mm	mm	mm	mm				PKMNSHO	mm	mm	mm	mm	mm	

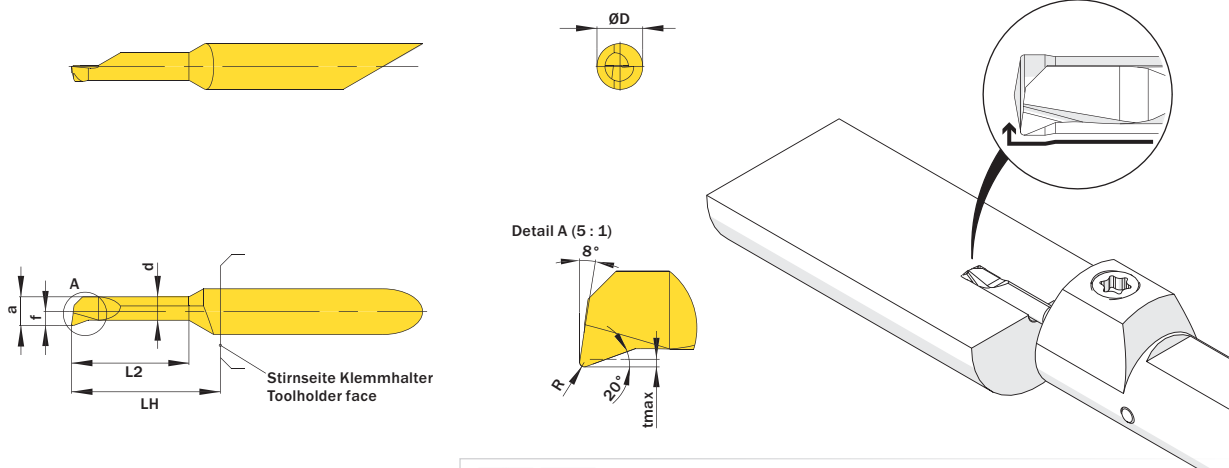
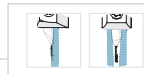
Fortgesetzte Tabelle
Continued Table

Verwandte Werkzeuge finden Sie auch auf der vorhergehenden Seite!
Related items can be found on the previous page as well!

▼ ØDmin (Min. Bohrung) // ØDmin (min. bore) = 3,0 mm														
4,0	15,2	3,0	0,15	+	A04.1C14.15.30.15 YR/L	R AW3S L AW3Q	X800 X400 X600	GX79 X500 X400	2,75	2,35	1,95	18,0	0,2	R A04C.R L A04C.L
4,0	20,3	3,0	0,15	•	A04.1814.20.30.15 YR/L	R APP5 L AMU6	X800 X400 X600	GX79 X500 X400	2,75	2,35	1,35	23,0	0,2	R A04.R L A04.L
4,0	20,3	3,0	0,15	+	A04.1C14.20.30.15 YR/L	R AHQ2 L AKT4	X800 X400 X600	GX79 X500 X400	2,75	2,35	1,95	23,0	0,2	R A04C.R L A04C.L
4,0	25,4	3,0	0,05	•	A04.1814.25.30.05 YR/L	R ATVX L AVEY	X800 X400 X600	GX79 X500 X400	2,75	2,35	1,35	28,0	0,2	R A04.R L A04.L
4,0	25,4	3,0	0,05	+	A04.1C14.25.30.05 YR/L	R AW9T L AXAM	X800 X400 X600	GX79 X500 X400	2,75	2,35	1,95	28,0	0,2	R A04C.R L A04C.L
▼ ØDmin (Min. Bohrung) // ØDmin (min. bore) = 3,2 mm														
4,0	10,2	3,2	0,03	•	A04.1815.10.32.03 YR/L	R AM5F L AH7Q	X800 X400 X600	GX79 X500 X400	2,95	2,55	1,45	13,0	0,2	R A04.R L A04.L
4,0	10,2	3,2	0,03	+	A04.1C15.10.32.03 YR/L	R AW9V L AXAP	X800 X400 X600	GX79 X500 X400	2,95	2,55	1,95	13,0	0,2	R A04C.R L A04C.L
4,0	10,2	3,2	0,05	•	A04.1815.10.32.05 YR/L	R ACMP L AMPB	X800 X400 X600	GX79 X500 X400	2,95	2,55	1,45	13,0	0,2	R A04.R L A04.L
4,0	10,2	3,2	0,05	+	A04.1C15.10.32.05 YR/L	R AW9W L AXAQ	X800 X400 X600	GX79 X500 X400	2,95	2,55	1,95	13,0	0,2	R A04C.R L A04C.L
4,0	10,2	3,2	0,15	•	A04.1815.10.32.15 YR/L	R ANAV L AKDJ	X800 X400 X600	GX79 X500 X400	2,95	2,55	1,45	13,0	0,2	R A04.R L A04.L
4,0	10,2	3,2	0,15	+	A04.1C15.10.32.15 YR/L	R AG17 L AC37	X800 X400 X600	GX79 X500 X400	2,95	2,55	1,95	13,0	0,2	R A04C.R L A04C.L
4,0	15,2	3,2	0,05	•	A04.1815.15.32.05 YR/L	R AHFZ L AAS8	X800 X400 X600	GX79 X500 X400	2,95	2,55	1,45	18,0	0,2	R A04.R L A04.L
4,0	15,2	3,2	0,05	+	A04.1C15.15.32.05 YR/L	R AW9X L AXAS	X800 X400 X600	GX79 X500 X400	2,95	2,55	1,95	18,0	0,2	R A04C.R L A04C.L
4,0	15,2	3,2	0,15	•	A04.1815.15.32.15 YR/L	R APP9 L AFNG	X800 X400 X600	GX79 X500 X400	2,95	2,55	1,45	18,0	0,2	R A04.R L A04.L
4,0	15,2	3,2	0,15	+	A04.1C15.15.32.15 YR/L	R ABTG L AAWS	X800 X400 X600	GX79 X500 X400	2,95	2,55	1,95	18,0	0,2	R A04C.R L A04C.L
4,0	20,3	3,2	0,05	•	A04.1815.20.32.05 YR/L	R APGP L AFHA	X800 X400 X600	GX79 X500 X400	2,95	2,55	1,45	23,0	0,2	R A04.R L A04.L
4,0	20,3	3,2	0,05	+	A04.1C15.20.32.05 YR/L	R AW9Y L AXAT	X800 X400 X600	GX79 X500 X400	2,95	2,55	1,95	23,0	0,2	R A04C.R L A04C.L
4,0	20,3	3,2	0,15	•	A04.1815.20.32.15 YR/L	R AQC L ABZB	X800 X400 X600	GX79 X500 X400	2,95	2,55	1,45	23,0	0,2	R A04.R L A04.L
4,0	20,3	3,2	0,15	+	A04.1C15.20.32.15 YR/L	R AAUV L ADEU	X800 X400 X600	GX79 X500 X400	2,95	2,55	1,95	23,0	0,2	R A04C.R L A04C.L
4,0	25,4	3,2	0,15	+	A04.1C15.25.32.15 YR	A2AD	X800 X400 X600	GX79 X500 X400	2,95	2,55	1,95	28,0	0,2	A04C.R

Verwandte Werkzeuge finden Sie auch auf der folgenden Seite!
Related items can be found on the following page as well!

Fortgesetzte Tabelle
Continued Table

Bestellbeispiel // Order example: A04.1815.10.32.15 YR X800 (R = Rechte Ausführung // Right hand version, X800 = Schneidstoff // Grade)